

F110-P

FLOWRATE INDICATOR / TOTALIZER

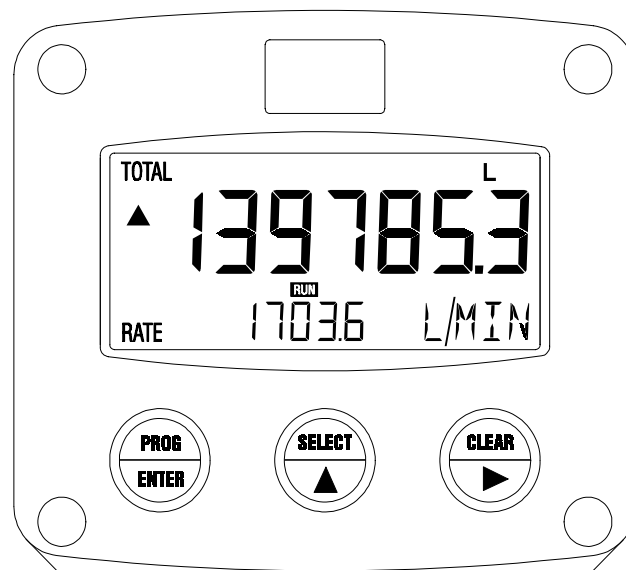

Signal input flowmeter: pulse, namur and coil.

Signal outputs: 4-20mA ref. flowrate and pulse ref. total.

Options: Intrinsically Safe, Modbus communication, external reset and backlight.



SAFETY INSTRUCTIONS



- **Any responsibility is lapsed if the instructions and procedures as described in this manual are not followed.**



- **LIFE SUPPORT APPLICATIONS: The F110-P is not designed for use in life support appliances, devices, or systems where malfunction of the product can reasonably be expected to result in a personal injury. Customers using or selling these products for use in such applications do so at their own risk and agree to fully indemnify the manufacturer and supplier for any damages resulting from such improper use or sale.**



- **Electro static discharge does inflict irreparable damage to electronics! Before installing or opening the unit, the installer has to discharge himself by touching a well-grounded object.**



- **This unit must be installed in accordance with the EMC guidelines (Electro Magnetic Compatibility).**



- **Do connect a proper grounding to the aluminum casing (option HA/HU) as indicated if the F110-P has been supplied with the 115-230V AC power-supply option PM. The green/yellow wire between the back-casing and removable terminal-block may never be removed.**



- **Intrinsically Safe applications: follow the instructions as mentioned in Chapter 5.**

SAFETY RULES AND PRECAUTIONARY MEASURES

- The manufacturer accepts no responsibility whatsoever if the following safety rules and precautions instructions and the procedures as described in this manual are not followed.
- Modifications of the F110-P implemented without preceding written consent from the manufacturer, will result in the immediate termination of product liability and warranty period.
- Installation, use, maintenance and servicing of this equipment must be carried out by authorized technicians.
- Check the mains voltage and information on the manufacturer's plate before installing the unit.
- Check all connections, settings and technical specifications of the various peripheral devices with the F110-P supplied.
- Open the casing only if all leads are free of potential.
- Never touch the electronic components (ESD sensitivity).
- Never expose the system to heavier conditions than allowed according to the casing classification (see manufacture's plate and chapter 4.2.).
- If the operator detects errors or dangers, or disagrees with the safety precautions taken, then inform the owner or principal responsible.
- The local labor and safety laws and regulations must be adhered to.

ABOUT THE OPERATION MANUAL

This operation manual is divided into two main sections:

- The daily use of the unit is described in chapter 2 "Operation". These instructions are meant for users.
- The following chapters and appendices are exclusively meant for electricians/technicians. These provide a detailed description of all software settings and hardware installation guidance.

This operation manual describes the standard unit as well as most of the options available. For additional information, please contact your supplier.

A hazardous situation may occur if the F110-P is not used for the purpose it was designed for or is used incorrectly. Please carefully note the information in this operating manual indicated by the pictograms:



A "**warning**" indicates actions or procedures which, if not performed correctly, may lead to personal injury, a safety hazard or damage of the F110-P or connected instruments.



A "**caution**" indicates actions or procedures which, if not performed correctly, may lead to personal injury or incorrect functioning of the F110-P or connected instruments.



A "**note**" indicates actions or procedures which, if not performed correctly, may indirectly affect operation or may lead to an instrument response which is not planned.

Hardware version	:	02.01.xx
Software version	:	02.02.xx
Manual	:	HF110PEN_v0204_10.doc

Information in this manual is subject to change without prior notice. The manufacturer is not responsible for mistakes in this material or for incidental damage caused as a direct or indirect result of the delivery, performance or use of this material.

© All rights reserved. No parts of this publication may be reproduced or used in any form or by any means without written permission of your supplier.

CONTENTS MANUAL

Safety instructions	1
Safety rules and precautionary measures	2
About the operation manual.....	3
Contents manual.....	4
1. Introduction.....	5
1.1. System description of the F110-P	5
2. Operational.....	7
2.1. General	7
2.2. Control panel.....	7
2.3. Operator information and functions.....	8
3. Configuration	10
3.1. Introduction	10
3.2. Programming SETUP-level.....	10
3.2.1. General	10
3.2.2. Overview functions SETUP level	13
3.2.3. Explanation OF SETUP-functions.....	14
1 - Total	14
2 - Flowrate	15
3 - Display	16
4 - Power management.....	16
5 - Flowmeter	17
6 - Analog output.....	18
6 - Analog output (continued)	19
7 - Relay output.....	19
8 - Communication (optional).....	20
9 - Others	20
4. Installation	21
4.1. General directions	21
4.2. Installation / surrounding conditions.....	21
4.3. Dimensions- Enclosure	22
4.4. Installing the hardware.....	23
4.4.1. Introduction	23
4.4.2. Voltage selection sensor supply	24
4.4.3. Terminal connectors	25
5. Intrinsically safe applications.....	33
6. Maintenance.....	43
6.1. General directions	43
Appendix A: Technical specification	44
Appendix B: Problem solving.....	47
Appendix C: Communication variables.....	48
Index of this manual.....	51
List of figures in this manual	51

1. INTRODUCTION

1.1. SYSTEM DESCRIPTION OF THE F110-P

Functions and features

The flowrate / totalizer model F110-P is a microprocessor driven instrument designed to display flowrate, total and accumulated total.

This product has been designed with a focus on:

- ultra-low power consumption to allow long-life battery powered applications (option PB),
- intrinsic safety for use in hazardous applications (option XI),
- several mounting possibilities with ABS or aluminum enclosures for harsh industrial surroundings,
- ability to process all types of flowmeter signals,
- transmitting possibilities with analog / pulse and communication (option) outputs.

Flowmeter input

This manual describes the unit with a pulse type input from the flowmeter "-P version". Other versions are available to process (0)4-20mA or 0-10V flowmeter signals.

One flowmeter with a passive or active pulse, Namur or coil signal output can be connected to the F110-P. To power the sensor, several options are available.

Standard outputs

- Configurable pulse output: a scaled pulse mirroring a certain totalised quantity. Maximum frequency 60Hz.; the pulse length can be set from 7,8msec up to 2 seconds.
- Configurable passive linear 4-20mA analog output with 10-bits resolution mirroring the actual flowrate. Flowrate levels as well as the minimum and maximum signal output can be tuned.

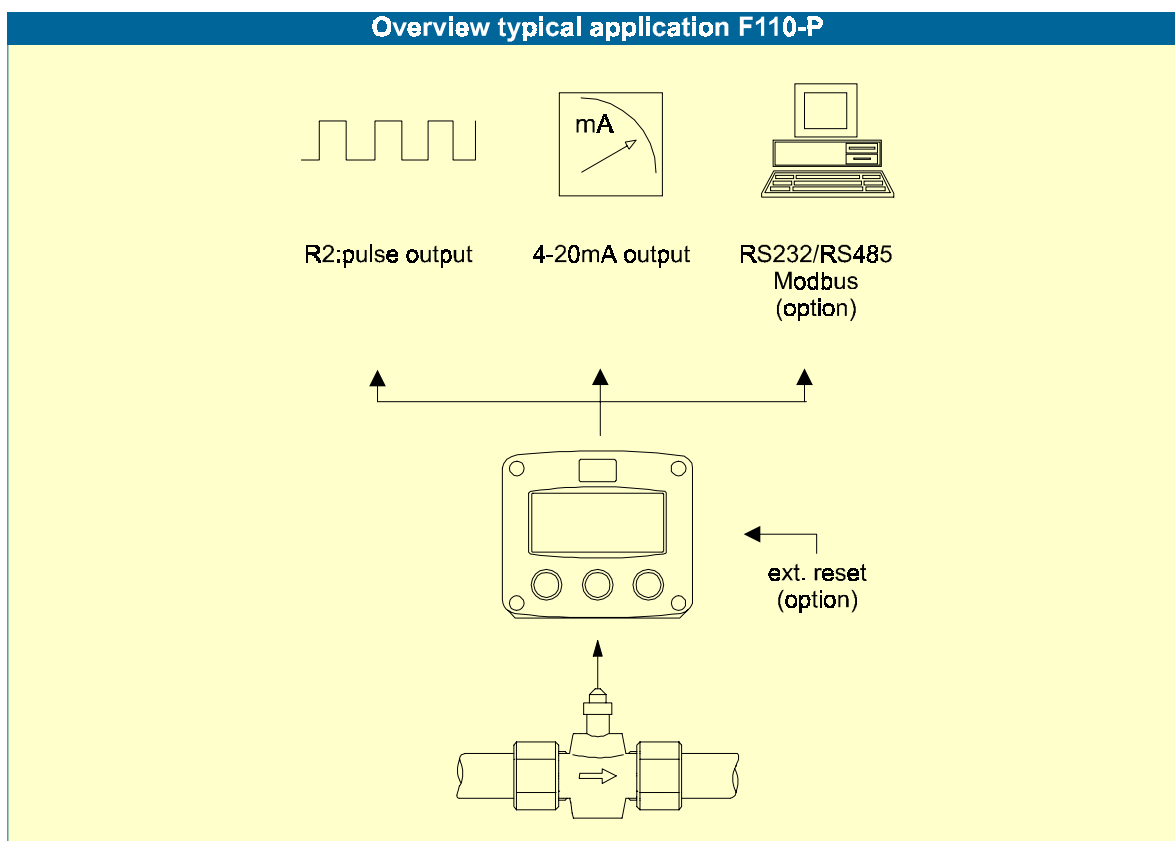

Fig. 1: Typical application for the F110-P.

Configuration of the unit

The F110-P was designed to be implemented in many types of applications. For that reason, a SETUP-level is available to configure your F110-P according to your specific requirements. SETUP includes several important features, such as K-factors, measurement units, signal selection etc. All settings are stored in EEPROM memory and will not be lost in the event of power failure or a drained battery.

To extend the battery-life time (option), please make use of the power-management functions as described in chapter 3.2.3.

Display information

The unit has a large transfective LCD with all kinds of symbols and digits to display measuring units, status information, trend-indication and key-word messages.

Flowrate and totals can be displayed either with the small 8mm digits or with the 17mm digits.

A backup of the total and accumulated total in EEPROM memory is made every minute.

Options

The following options are available: isolated or active 4-20mA / 0-10V / 0-20mA analog output, full Modbus communication RS232/485 (also battery powered), intrinsic safety, mechanical relay or active outputs, power- and sensor-supply options, panel-mount, wall-mount and weather-proof enclosures, flame proof enclosure and LED backlight.

2. OPERATIONAL

2.1. GENERAL



- *The F110-P may only be operated by personnel who are authorized and trained by the operator of the facility. All instructions in this manual are to be observed.*
- *Take careful notice of the " Safety rules, instructions and precautionary measures " in the front of this manual.*

This chapter describes the daily use of the F110-P. This instruction is meant for users / operators.

2.2. CONTROL PANEL

The following keys are available:

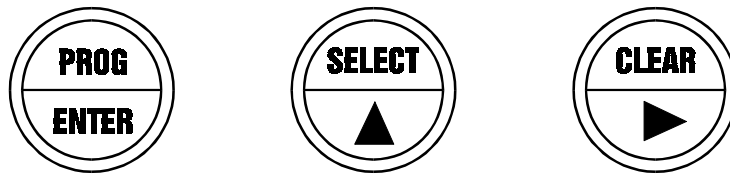

Fig. 2: Control Panel.

Functions of the keys



This key is used to program and save new values or settings.
It is also used to gain access to SETUP-level; please read chapter 3.



This key is used to SELECT accumulated total.
The arrow-key \blacktriangle is used to increase a value after PROG has been pressed or to configure the unit; please read chapter 3.



Press this key twice to CLEAR the value for total.
The arrow-key \blacktriangleright is used to select a digit after PROG has been pressed or to configure the unit; please read chapter 3.

2.3. OPERATOR INFORMATION AND FUNCTIONS

In general, the F110-P will always function at Operator level. The information displayed is dependant upon the SETUP-settings. All pulses generated by the connected flowmeter are measured by the F110-P in the background, whichever screen refresh rate setting is chosen. After pressing a key, the display will be updated very quickly during a 30 second period, after which it will slow-down again.



Fig. 3: Example of display information during process.

For the Operator, the following functions are available:

- **Display flowrate / total or flowrate**
This is the main display information of the F110-P. After selecting any other information, it will always return to this main display automatically.
Total is displayed on the upper-line of the display and flowrate on the bottom line.
It is possible to display flowrate only with the large 17mm digits; in this instance press the SELECT-key to read the total.
When "-----" is shown, then the flowrate value is too high to be displayed. The arrows \blacktriangleleft \blacktriangleright indicate the increase/decrease of the flowrate trend.
- **Clear total**
The value for total can be re-initialized. To do so, press CLEAR twice. After pressing CLEAR once, the flashing text "PUSH CLEAR" is displayed. To avoid re-initialization at this stage, press another key than CLEAR or wait for 20 seconds.
Re-initialization of total DOES NOT influence the accumulated total.
- **Display accumulated total**
When the SELECT-key is pressed, total and accumulated total are displayed. The accumulated total cannot be re-initialized. The value will count up to 99,999,999,999. The unit and number of decimals are displayed according to the configuration settings for total.

- **Low-battery alarm**

When the battery voltage drops, it must be replaced. At first "low-battery" will flash, but as soon as it is displayed continuously, the battery MUST be replaced shortly after!

Only official batteries may be used, or else the guarantee will be terminated. The remaining lifetime after the first moment of indication is generally several days up to some weeks.



Fig. 4: Example of low-battery alarm.

- **Alarm 01-03**

When "alarm" is displayed, please consult Appendix B: problem solving.

3. CONFIGURATION

3.1. INTRODUCTION

This and the following chapters are exclusively meant for electricians and non-operators. In these, an extensive description of all software settings and hardware connections are provided.



- **Mounting, electrical installation, start-up and maintenance of the instrument may only be carried out by trained personnel authorized by the operator of the facility. Personnel must read and understand this Operating Manual before carrying out its instructions.**
- **The F110-P may only be operated by personnel who are authorized and trained by the operator of the facility. All instructions in this manual are to be observed.**
- **Ensure that the measuring system is correctly wired up according to the wiring diagrams. The housing may only be opened by trained personnel.**
- **Take careful notice of the " Safety rules, instructions and precautionary measures " in the front of this manual.**

3.2. PROGRAMMING SETUP-LEVEL

3.2.1. GENERAL

Configuration of the F110-P is done at SETUP-level. SETUP-level is reached by pressing the PROG/ENTER key for 7 seconds; at which time, both arrows \blacktriangle will be displayed. In order to return to the operator level, PROG will have to be pressed for three seconds. Alternatively, if no keys are pressed for 2 minutes, the unit will exit SETUP automatically. SETUP can be reached at all times while the F110-P remains fully operational.



Note: A pass code may be required to enter SETUP. Without this pass code access to SETUP is denied.

To enter SETUP-level:

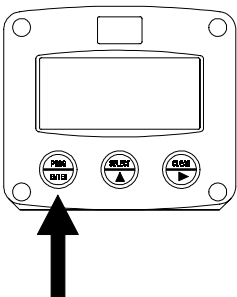

Press  for 7 seconds

Matrix structure SETUP-level:

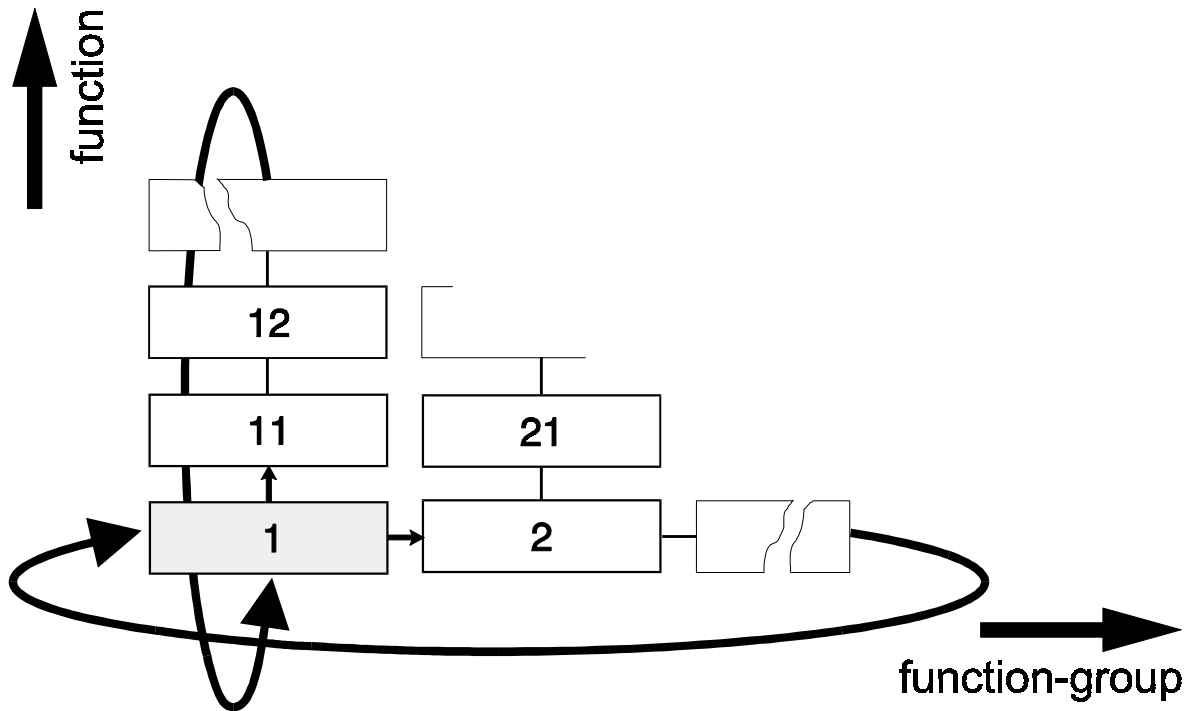

SCROLLING THROUGH SETUP-LEVEL

Selection of function-group and function:

SETUP is divided into several function groups and functions.

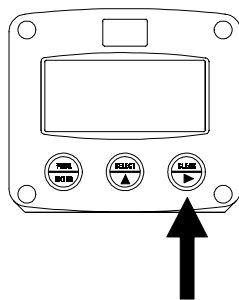

Select function-group with

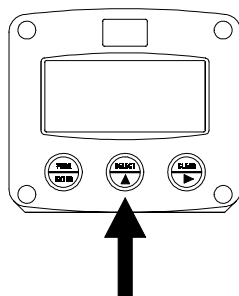

Select function with







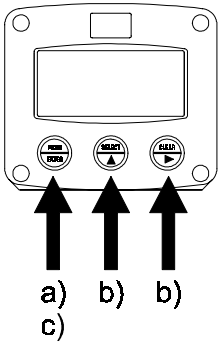

Each function has a unique number, which is displayed below the word "SETUP" at the bottom of the display. The number is a combination of two figures. The first figure indicates the function-group and the second figure the sub-function. Additionally, each function is expressed with a keyword.



After selecting a sub-function, the next main function is selected by scrolling through all "active" sub-functions (e.g. 1[▲], 11[▲], 12[▲], 13[▲], 14[▲], 1[▶], 2[▶], 3[▲], 31 etc.).



To change or select a value:



- a) press  briefly; **PROGRAM** will start flash
- b) select or enter value with  and / or 
- c) press  to confirm the value / selection.

To change a value, use  to select the digits and  to increase that value.

To select a setting, both  and  can be used.

If the new value is invalid, the increase sign  or decrease-sign  will be displayed while you are programming.

When data is altered but ENTER is not pressed, then the alteration can still be cancelled by waiting for 20 seconds or by pressing ENTER for three seconds: the PROG-procedure will be left automatically and the former value reinstated.



Note: alterations will only be set after ENTER has been pressed!

To return to OPERATOR-level:

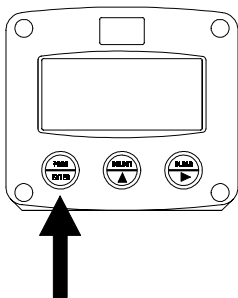

Press  for 3 seconds

In order to return to the operator level, PROG will have to be pressed for three seconds. Also, when no keys are pressed for 2 minutes, SETUP will be left automatically.

3.2.2. OVERVIEW FUNCTIONS SETUP LEVEL

SETUP FUNCTIONS AND VARIABLES			
1	TOTAL		
	11	UNIT	L - m3 - kg - lb - GAL - USGAL - bbl - no unit
	12	DECIMALS	0 - 1 - 2 - 3 (Ref: displayed value)
	13	K-FACTOR:	0.000010 - 9,999,999
	14	DECIMALS K-FACTOR	0 - 6
2	FLOWRATE		
	21	UNIT	mL - L - m3 - mg - g - kg - ton - GAL - bbl - lb - cf - REV - no unit - scf - Nm3 - NL - P
	22	TIME UNIT	sec - min - hour - day
	23	DECIMALS	0 - 1 - 2 - 3 (Ref: displayed value)
	24	K-FACTOR	0.000010 - 9,999,999
	25	DECIMALS K-FACTOR	0 - 6
	26	CALCULATION	per 1 - 255 pulses
	27	CUT-OFF	0.1 - 999.9 seconds
3	DISPLAY		
	31	FUNCTION	total - flowrate
4	POWER MANAGEMENT		
	41	LCD UPDATE	fast - 1 sec - 3 sec - 15 sec - 30 sec - off
	42	BATTERY MODE	operational - shelf
5	FLOWMETER		
	51	SIGNAL	nnp - nnp_lp - reed - reed_lp - pnp - pnp_lp - namur - coil_hi - coil_lo - act_8.1 - act_12 - act_24
6	ANALOG		
	61	OUTPUT	disable - enable
	62	4mA / 0V	0000.000 - 9,999,999
	63	20mA / 10V	0000.000 - 9,999,999
	64	CUT-OFF	0.0 - 9.9%
	65	TUNE MIN - 4mA / 0V	0 - 9,999
	66	TUNE MAX- 20mA / 10V	0 - 9,999
	67	FILTER	00 - 99
7	IMPULSE		
	71	PERIOD TIME	0 - 250
	72	IMPULSE PER	X,XXX,XXX quantity
8	COMMUNICATION		
	81	SPEED / BAUDRATE	1200 - 2400 - 4800 - 9600
	82	ADDRESS	1 - 255
	83	MODE	ASCII - rtu - off
9	OTHERS		
	91	TYPE / MODEL	
	92	SOFTWARE VERSION	
	93	SERIAL NO.	
	94	PASS CODE	0000 - 9999
	95	TAGNUMBER	0000000 - 9999999

3.2.3. EXPLANATION OF SETUP-FUNCTIONS

1 - TOTAL	
MEASUREMENT UNIT 11	<p>SETUP - 11 determines the measurement unit for total, accumulated total and pulse output. The following units can be selected:</p> <p style="text-align: center;">L - m3 - kg - lb. - GAL - USGAL - bbl - _ (no unit).</p> <p>Alteration of the measurement unit will have consequences for operator and SETUP-level values. Please note that the K-factor has to be adapted as well; the calculation is not done automatically.</p>
DECIMALS 12	<p>The decimal point determines for total, accumulated total and pulse output the number of digits following the decimal point. The following can be selected:</p> <p style="text-align: center;">0000000 - 111111.1 - 22222.22 - 3333.333</p>
K-FACTOR 13	<p>With the K-factor, the flowmeter pulse signals are converted to a quantity. The K-factor is based on the number of pulses generated by the flowmeter per selected measurement unit (SETUP 11), for example per cubic meter. The more accurate the K-factor, the more accurate the functioning of the system will be.</p> <p>Example 1: Calculating the K-factor. <i>Let us assume that the flowmeter generates 2.4813 pulses per liter and the selected unit is "cubic meters / m3". A cubic meter consists of 1000 parts of one liter which implies 2,481.3 pulses per m3. So, the K-factor is 2,481.3. Enter for SETUP - 13: "2481300" and for SETUP - 14 - decimals K-factor "3".</i></p> <p>Example 2: Calculating the K-factor. <i>Let us assume that the flowmeter generates 6.5231 pulses per gallon and the selected measurement unit is gallons. So, the K-Factor is 6.5231. Enter for SETUP - 13: "6523100" and for SETUP - 14 decimals K-factor "6".</i></p>
DECIMALS K-FACTOR 14	<p>This setting determines the number of decimals for the K-factor entered. (SETUP 13). The following can be selected:</p> <p style="text-align: center;">0 - 1 - 2 - 3 - 4 - 5 - 6</p> <p>Please note that this setting influences the accuracy of the K-factor indirectly. (i.e. the position of the decimal point and thus the value given) This setting has NO influence on the displayed number of digits for total (SETUP 12)!</p>

2 - FLOWRATE

The settings for total and flowrate are entirely separate. In this way, different units of measurement can be used for each e.g. cubic meters for total and liters for flowrate. The display update time for flowrate is one second or more.

Note: these settings also influence the analog output.

MEASUREMENT UNIT 21	<p>SETUP - 21 determines the measurement unit for flowrate. The following units can be selected:</p> <p style="text-align: center;">mL - L - m3 - mg - g - kg - ton - GAL - bbl - lb - cf - REV - no unit - scf - Nm3 - NL - P.</p> <p>Alteration of the measurement unit will have consequences for operator and SETUP-level values. Please note that the K-factor has to be adapted as well; the calculation is not done automatically.</p>
TIME UNIT 22	The flowrate can be calculated per second (SEC), minute (MIN), hour (HR) or day (DAY).
DECIMALS 23	<p>This setting determines for flowrate the number of digits following the decimal point. The following can be selected:</p> <p style="text-align: center;">00000 - 1111.1 - 2222.22 - 3333.333</p>
K-FACTOR 24	With the K-factor, the flowmeter pulse signals are converted to a flowrate. The K-factor is based on the number of pulses generated by the flowmeter per selected measurement unit (SETUP 21), for example per liter. The more accurate the K-factor, the more accurate the functioning of the system will be. For examples read SETUP 13.
DECIMALS K-FACTOR 25	<p>This setting determines the number of decimals for the K-factor (SETUP 24). The following can be selected:</p> <p style="text-align: center;">0 - 1 - 2 - 3 - 4 - 5 - 6</p> <p>Please note that this SETUP - influences the accuracy of the K-factor indirectly. This setting has NO influence on the displayed number of digits for "flowrate" (SETUP 23)!</p>
CALCULATION 26	<p>The flowrate is calculated by measuring the time between a number of pulses, for example 10 pulses. The more pulses the more accurate the flowrate will be. The maximum value is 255 pulses.</p> <p>Note: this setting does influence the update time for the analog output directly (maximum update 10 times a second). If the output response is too slow, decrease the number of pulses.</p> <p>Note: the lower the number of pulses, the higher the power consumption of the unit will be (important for battery powered applications).</p> <p>Note: for low frequency applications (below 10Hz): do not program more than 10 pulses else the update time will be very slow.</p> <p>Note: for high frequency application (above 1kHz) do program a value of 50 or more pulses.</p>
CUT-OFF TIME 27	<p>With this setting, you determine a minimum flow requirement threshold, if during this time less than XXX-pulses (SETUP 26) are generated, the flowrate will be displayed as zero.</p> <p>The cut-off time has to be entered in seconds - maximum time is 999 seconds (about 15 minutes).</p>



Note !

3 - DISPLAY

FUNCTION 31	The large 17mm digits can be set to display total or flowrate. When "total" is selected, both total and flowrate are displayed simultaneously. When "flowrate" is selected, only flowrate will be displayed with it's measuring unit while total will be displayed after pressing SELECT.
-----------------------	---

4 - POWER MANAGEMENT

When used with the internal battery option, the user can expect reliable measurement over a long period of time. The F110-P has several smart power management functions to extend the battery life time significantly. Two of these functions can be set:

LCD NEW 41	<p>The calculation of the display-information influences the power consumption significantly. When the application does not require a fast display update, it is <u>strongly advised</u> to select a slow refresh rate. Please understand that NO information will be lost; every pulse will be counted and the output signals will be generated in the normal way. The following can be selected:</p> <p style="text-align: center;">Fast - 1 sec - 3 sec - 15 sec - 30 sec - off.</p> <p>Example 3: Battery life-time <i>battery life-time with a coil pick-up, 1KHz. pulses and FAST update: about 2 years.</i> <i>battery life-time with a coil pick-up, 1KHz. pulses and 1 sec update: about 5 years.</i></p> <p>Note: <i>after a button has been pressed by the operator - the display refresh rate will always switch to FAST for 30 seconds. When "OFF" is selected, the display will be switched off after 30 seconds and will be switched on as soon as a button has been pressed.</i></p>
BATTERY-MODE 42	<p>The unit has two modes: operational or shelf. After "shelf" has been selected, the unit can be stored for several years; it will not count pulses, the display is switched off but all settings and totals are stored. In this mode, power consumption is extremely low. To wake up the unit again, press the SELECT-key twice.</p>



Note !

5 - FLOWMETER

TYPE OF SIGNAL	EXPLANATION	RESISTANCE	FREQ. / mV	REMARK
SIGNAL 51	The F110-P is able to handle several types of input signal. The type of flowmeter pickup / signal is selected with SETUP 51. Note: The selections "active pulse" offer a detection level of 50% of the supply voltage. Read also par. 4.4.3. Flowmeter input terminal 09-11.			
NPN	NPN input	100K pull-up	6 kHz.	(open collector)
NPN - LP	NPN input with low pass filter	100K pull-up	2.2 kHz.	(open collector) less sensitive
REED	Reed-switch input	1M pull-up	1.2 kHz.	
REED - LP	Reed-switch input with low pass filter	1M pull-up	120 Hz.	Less sensitive
PNP	PNP input	100K pull-down	6 kHz.	
PNP - LP	PNP input with low pass filter	100K pull-down	700 Hz.	Less sensitive
NAMUR	Namur input	820 Ohm pull-down	4 kHz.	External power required
COIL HI	High sensitive coil input	-	20mV p.t.p.	Sensitive for disturbance!
COIL LO	Low sensitive coil input	-	90mV p.t.p.	Normal sensitivity
ACT_8.1	Active pulse input 8.1 VDC	3K9	10KHz.	External power required
ACT_12	Active pulse input 12 VDC	4K	10KHz.	External power required
ACT_24	Active pulse input 24 VDC	3K	10KHz.	External power required



Note !

6 - ANALOG OUTPUT

A linear 4-20mA signal (option AB: 0-20mA or option AU: 0-10V) output signal is generated according to the flowrate with a 10 bits resolution. The settings for flowrate (SETUP - 2) directly influence the analog output.

Note: When the analog output is not used, please make sure that setting 61 is disabled, or else the battery life time will be reduced significantly!

When a power supply is available but the output is disabled, a 3.5mA signal will be generated.

The relationship between rate and analog output is set with the following functions:



Note !

DISABLE / ENABLE 61	The D/A converter has a relatively high power consumption. If the analog output is not being used, select "disable" to switch-off the converter. For more information read par. 4.4.3.			
MINIMUM FLOWRATE 62	Enter here the flowrate at which the output should generate a 4mA signal (or 0mA / 0V) - in most applications at flowrate "zero". The number of decimals displayed depend upon SETUP 23. The time and measuring units (L/min for example) are dependant upon SETUP 21 and 22 but are not displayed.			
MAXIMUM FLOWRATE 63	Enter here the flowrate at which the output should generate a 20mA (or 10V) - in most applications at maximum flow. The number of decimals displayed depend upon SETUP 23. The time and measuring units (L/min for example) are dependant upon SETUP 21 and 22 but can not be displayed.			
CUT-OFF 64	To ignore leakage of the flow for example, a low flow cut-off can be set as a percentage of the full range of 16mA (or 20mA / 10V). When the flow is less than the required rate, the current will be 4mA. Examples:			
4mA (SETUP 62)	20mA (SETUP 63)	CUT-OFF (SETUP 64)	REQUIRED RATE	OUTPUT
0 L/min	100 L/min	2%	$(100-0)*2\% = 2.0 \text{ L/min}$	$4+(16*2\%) = 4.32\text{mA}$
20 L/min	800 L/min	3.5%	$(800-20)*3.5\% = 27.3 \text{ L/min}$	$4+(16*3.5\%) = 4.56\text{mA}$

TUNE MIN / 4MA 65	<p>The initial minimum analog output value is 4mA (or 0mA / 0V). However, this value might differ slightly due to external influences such as temperature for example. The 4mA value (or 0mA / 0V) can be tuned precisely with this setting.</p> <ul style="list-style-type: none"> ▪ Before tuning the signal, be sure that the analog signal is not being used for any application! <p>After pressing PROG, the current will be about 4mA (or 0mA / 0V). The current can be increased/decreased with the arrow-keys and is <u>directly active</u>. Press ENTER to store the new value.</p>
------------------------------	--



TUNE MAX / 20MA 66	<p>The initial maximum analog output value is 20mA (or 10V). However, this value might differ slightly due to external influences such as temperature for example. The 20mA value (or 10V) can be tuned precisely with this setting.</p> <ul style="list-style-type: none"> ▪ Before tuning the signal, be sure that the analog signal is not being used for any application! <p>After pressing PROG, the current will be about 20mA. The current can be increased/decreased with the arrow-keys and is <u>directly active</u>. Press ENTER to store the new value.</p>
-------------------------------	---



Continued next page >>>

6 - ANALOG OUTPUT (CONTINUED)

FILTER 67	This function is used to stabilize the analog output signal. The output value is updated every 0.1 second. With the help of this digital filter a more stable but less precise reading can be obtained. The filter principal is based on three input values: the filter level (01-99), the last analog output value and the last average value. The higher the filter level, the longer the response time on a value change will be. Below, several filter levels with their response times are indicated:			
FILTER VALUE	RESPONSE TIME ON STEP CHANGE OF ANALOG VALUE. TIME IN SECONDS			
	50% INFLUENCE	75% INFLUENCE	90% INFLUENCE	99% INFLUENCE
01	filter disabled	filter disabled	filter disabled	filter disabled
02	0.1 second	0.2 second	0.4 second	0.7 second
03	0.2 second	0.4 second	0.6 second	1.2 seconds
05	0.4 second	0.7 second	1.1 seconds	2.1 seconds
10	0.7 second	1.4 seconds	2.2 seconds	4.4 seconds
20	1.4 seconds	2.8 seconds	4.5 seconds	9.0 seconds
30	2.1 seconds	4 seconds	7 seconds	14 seconds
50	3.5 seconds	7 seconds	11 seconds	23 seconds
75	5.2 seconds	10 seconds	17 seconds	34 seconds
99	6.9 seconds	14 seconds	23 seconds	45 seconds

7 - RELAY OUTPUT

One transistor or mechanic relay output is available as scaled pulse output according to the accumulated total.

PERIOD TIME PULSE OUTPUT 71	The period time determines the time that the transistor or relay will be switched; in other words the pulse length. The minimum time between the pulses is as long as the period time. One period is approx. 7.8 msec. If the value selected is "zero", the pulse output is disabled. The maximum value is 255 periods. Note: <i>If the frequency should go out of range - when the flowrate increases for example - an internal buffer will be used to "store the missed pulses": As soon as the flowrate reduces again, the buffer will be "emptied".</i> <i>It might be that pulses will be missed due to a buffer-overflow, so it is advised to program this setting within it's range</i>		
	NUMBER OF PERIODS	PERIOD TIME	MAX. FREQUENCY
	0	disabled	disabled
	1	0,0078 seconds	64 Hz.
	2	0,0156 seconds	32 Hz.
	3	0,0234 seconds	21 Hz.
	64	0,5000 seconds	1 Hz.
	255	1,9922 seconds	0.25 Hz.
PULSE PER 72	According to the measurement unit settings for total, a pulse will be generated every X-quantity. Enter this quantity here while taking the displayed decimal position and measuring unit into account.		



Note !

8 - COMMUNICATION (OPTIONAL)

The functions described below deal with hardware that is not part of the standard delivery. Programming of these functions does not have any effect if this hardware has not been installed. Consult Appendix C and the Modbus communication protocol description for a detailed explanation.

BAUDRATE 81	For external control, the following communication speeds can be selected: 1200 - 2400 - 4800 - 9600 baud
BUS ADDRESS 82	For communication purposes, a unique identity can be attributed to every F110-P. This address can vary from 1-255.
MODE 83	The communication protocol is Modbus ASCII or RTU mode. Select OFF, to disable this communication function.

9 - OTHERS

TYPE OF MODEL 91	For support and maintenance it is important to have information about the characteristics of the F110-P. Your supplier will ask for this information in the case of a serious breakdown or to assess the suitability of your model for upgrade considerations.
VERSION SOFTWARE 92	For support and maintenance it is important to have information about the characteristics of the F110-P. Your supplier will ask for this information in the case of a serious breakdown or to assess the suitability of your model for upgrade considerations.
SERIAL NUMBER 93	For support and maintenance it is important to have information about the characteristics of the F110-P. Your supplier will ask for this information in the case of a serious breakdown or to assess the suitability of your model for upgrade considerations.
PASS CODE 94	All SETUP-values can be pass code protected. This protection is disabled with value 0000 (zero). Up to and including 4 digits can be programmed, for example 1234.
TAGNUMBER 95	For identification of the unit and communication purposes, a unique tag number of maximum 7 digits can be entered.

4. INSTALLATION

4.1. GENERAL DIRECTIONS



- **Mounting, electrical installation, start-up and maintenance of this instrument may only be carried out by trained personnel authorized by the operator of the facility. Personnel must read and understand this Operating Manual before carrying out its instructions.**
- **The F110-P may only be operated by personnel who are authorized and trained by the operator of the facility. All instructions in this manual are to be observed.**
- **Ensure that the measuring system is correctly wired up according to the wiring diagrams. Protection against accidental contact is no longer assured when the housing cover is removed or the panel cabinet has been opened (danger from electrical shock). The housing may only be opened by trained personnel.**
- **Take careful notice of the " Safety rules, instructions and precautionary measures " at the front of this manual.**

4.2. INSTALLATION / SURROUNDING CONDITIONS

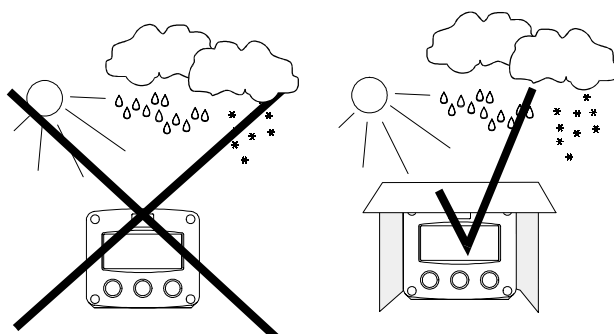

Take the relevant IP classification of the casing into account (see manufactures plate). Even an IP67 (NEMA 4X) casing should NEVER be exposed to strongly varying (weather) conditions.

When panel-mounted, the unit is IP65 (NEMA 4)!

When used in very cold surroundings or varying climatic conditions, take the necessary precautions against moisture by placing a dry sachet of silica gel, for example, inside the instrument case.

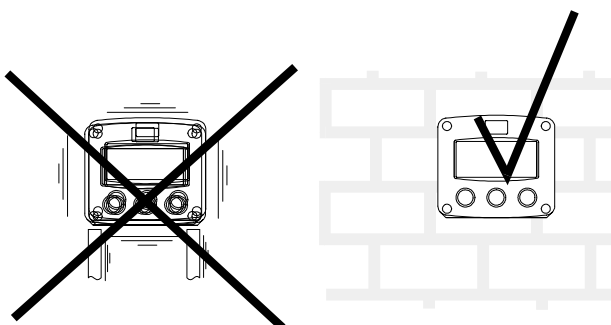

Mount the F110-P on a solid structure to avoid vibrations.

4.3. DIMENSIONS- ENCLOSURE

Standard IP65 (NEMA 4) ABS panel-mount enclosure:

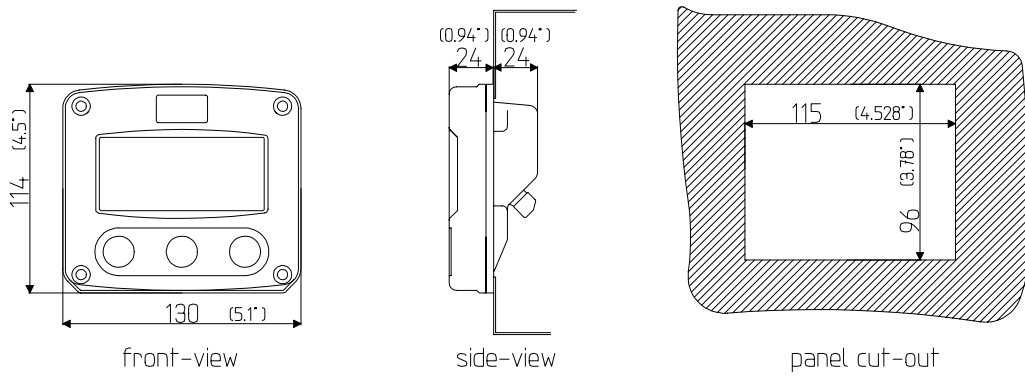

Fig. 5: Dimensions of standard IP65 ABS Panel-mount casing / panel cut-out.

Option HD: IP67 (NEMA 4X) ABS Wall-mount enclosure:

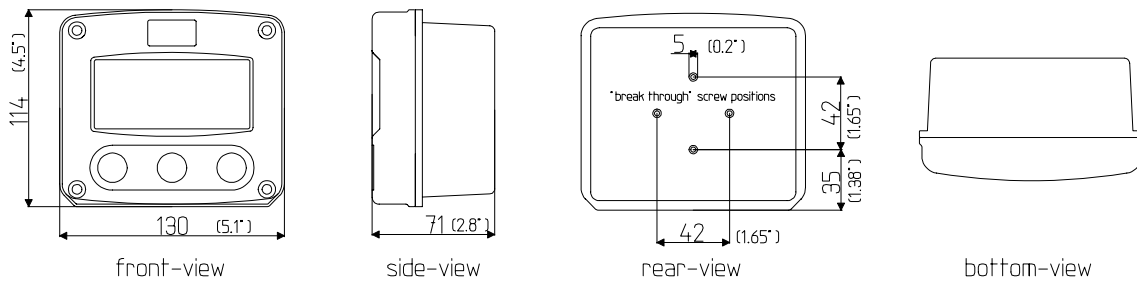

Fig. 6: Dimensions for option HD: IP67 ABS Wall-mount enclosure.

Option HA: IP67 Aluminum Field enclosure with 2xPG9 and 1xM20 Tapped holes:

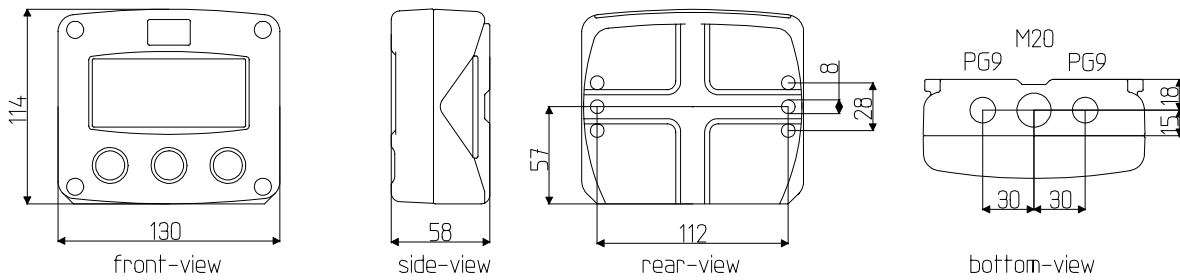

Fig. 7: Dimensions for option HA: IP67 Aluminum Field enclosure with 2xPG9 and 1xM20 drilling.

Option HU: NEMA 4X Aluminum Field enclosure with 3x 1/2" NPT Tapped holes:

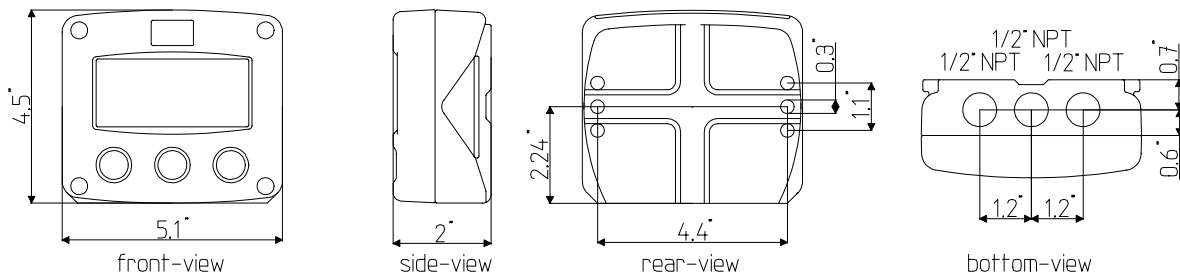

Fig. 8: Dimensions option HU: NEMA 4X Aluminum Field enclosure with 3x 1/2" NPT drilling.

4.4. INSTALLING THE HARDWARE

4.4.1. INTRODUCTION



- **Electro static discharge does inflict irreparable damage to electronics! Before installing or opening the unit, the installer has to discharge himself by touching a well-grounded object.**



- **This unit must be installed in accordance with the EMC guidelines (Electro Magnetic Compatibility).**



- **Do ground the aluminum casing properly (option HA / HU) as indicated, if the F110-P has been supplied with the 115-230V AC power-supply option PM. The green / yellow wire between the back-casing and removable terminal-block must never be removed.**

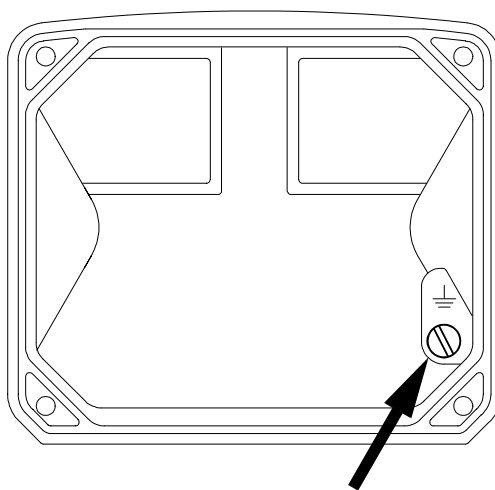

Fig. 9: Grounding aluminum enclosure with option PM 115-230V AC.

FOR INSTALLATION, PAY EMPHATIC ATTENTION TO:

- Separate cable glands with effective IP67 (NEMA4X) seals for all wires.
- Unused cable entries: ensure that you fit IP67 (NEMA4X) plugs to maintain rating.
- A reliable ground connection for both the sensor, and if applicable, for the metal casing. (above)
- An effective screened cable for the input signal, and grounding of it's screen to terminal 9 (GND) or at the sensor itself, whichever is appropriate to the application.

4.4.2. VOLTAGE SELECTION SENSOR SUPPLY

For *Intrinsically Safe* applications: read chapter 5.

Battery powered and output loop-powered applications:

Terminal 11 provides a limited supply voltage of 3.2 V DC (coil signals 1.2V) for the signal output of the flowmeter.

Note: This voltage *MAY NOT* be used to power the flowmeters electronics, converters etc, as it will not provide adequate sustained power ! All energy used by the flowmeters pick-up will directly influence the battery life-time. it is strongly advised to use a "zero power" pickup such as a coil or reed-switch when operating without external power. It is possible to use some low power NPN or PNP output signals, but the battery life time will be significantly reduced. (consult your distributor)



Option PD-PM: Sensor supply: 3.2V - 8.2V - 12V or 24 V:

With this option, a real power supply for the sensor is available. The flowmeter can be powered with 8.2 - 12 or 24 V DC (max. 50mA@24V). The voltage is selected by the three switches inside the enclosure.

- **Warning:** be sure that all the leads to the terminals are disconnected from the unit when the internal plastic protection cover has been removed !
- **HIGH VOLTAGE 400V !! NEVER** connect the mains power supply to the unit when the plastic protection cover has been removed !!!

First, remove the terminal strip(s) after which the internal plastic cover can be removed. The switches are located in the top left corner (option PD) or on the right hand (option PF / PM) as indicated:

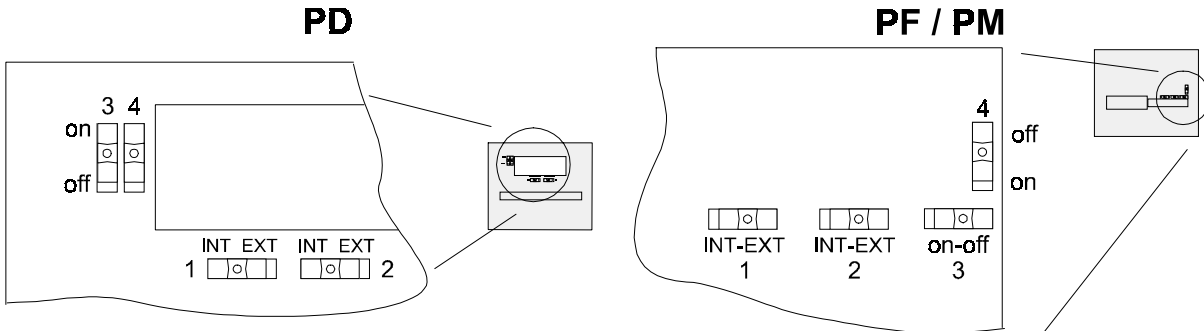

Fig. 10: switch position voltage selection (option PD, PF and PM).

Switch positions

SENSOR A	
SWITCH 1	VOLTAGE
internal	3.2 V DC
external	switch 3+4

SENSOR B	
SWITCH 2	VOLTAGE

VOLTAGE SELECTION		
SWITCH 3	SWITCH 4	VOLTAGE
on	on	8.2 V DC
off	on	12 V DC
on	off	12 V DC
off	off	23 V DC

Function switch 1: voltage selection sensor A - terminal 11.

Function switch 2: not available for this Model.

Function switch 3+4: the combination of these switches determine the voltage as indicated. If switch 1 and 2 are both set to position OFF than the selected voltage with switch 3+4 is valid for both sensors.

4.4.3. TERMINAL CONNECTORS

For *Intrinsically Safe* applications: read chapter 5.

The following terminal connectors are available:

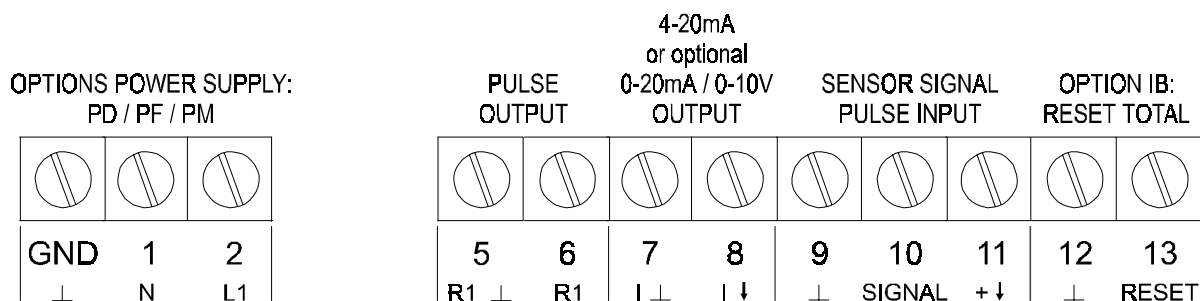

Fig. 11: Overview of terminal connectors standard configuration F110-P and options.

REMARKS: TERMINAL CONNECTORS:

Power Supply: Terminal GND- 01- 02 only available with option PD, PF or PM:

OPTION	SENSOR SUPPLY	Terminal			backlight	OPTION AA	OPTION AU	option OA	option OR
		GND	01	02					
PX 8-24V DC (AC)	1.2 - 3.2V	not available - use terminal 7 + 8							
PD 8-24V AC	1.2 -3.2-8.2-12-24V max 50mA		AC	AC		◇	◇	◇	
PD 8-30V DC	1.2 -3.2-8.2-12-24V max 50mA	L-	L+			◇	◇	◇	
PF 24V AC ± 15%	1.2 -3.2-8.2-12-24V max 100mA		AC	AC		◇	◇		◇
PF 24V DC ± 15%	1.2 -3.2-8.2-12-24V max 100mA	L-	L+			◇	◇		◇
PM 115-230V AC ± 15%	1.2 -3.2-8.2-12-24V max 100mA	EARTH	AC	AC		◇	◇	◇	◇

◇=option

For *Intrinsically Safe* applications: read chapter 5.

Terminal 05-06; transistor or relay output R1:

Setup 7 (par. 3.4.4.) determines the pulse output function. The maximum pulse frequency of this output is 60Hz. If a relay output option has been supplied, be sure that the output frequency does not exceed 5Hz or else the life-time of the relay will be reduced significantly.

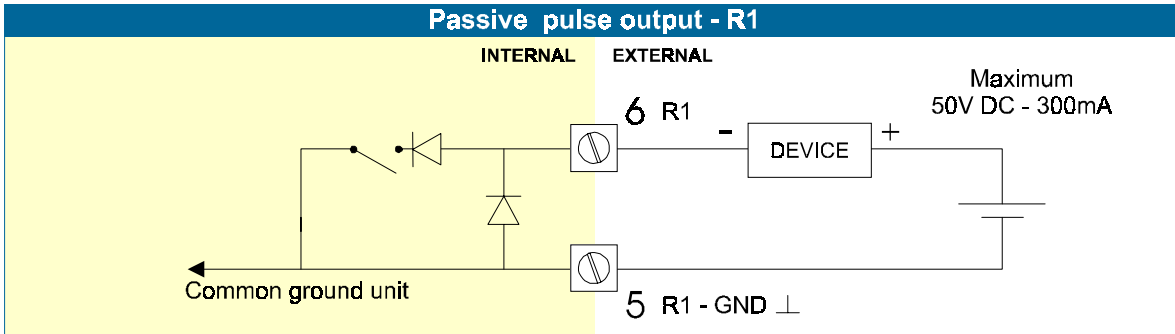

Option OA:

An active 24V DC signal pulse output is available with this option. Max. driving capacity 20mA@24V per output. (Requires power supply option PD / PF / PM).

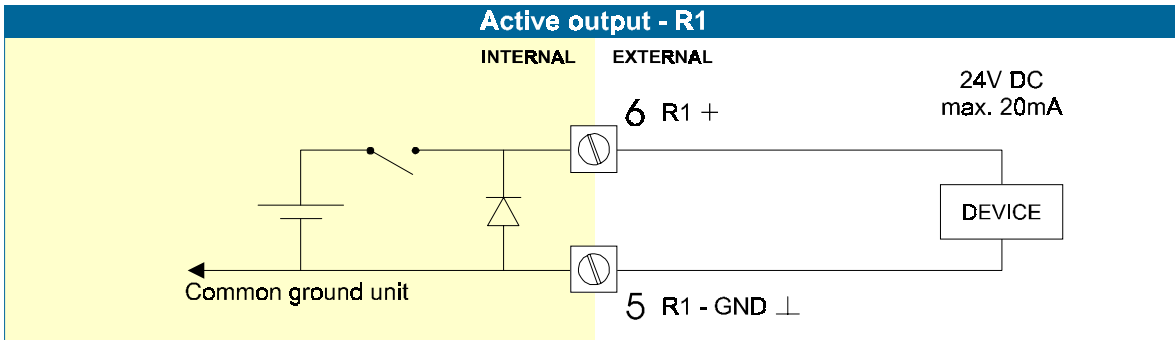

Option OR:

A mechanical relay output flowrate alarm output or pulse output is available with this option. Max. switch power 240V 0,5A per output. (Requires power supply option PF / PM).

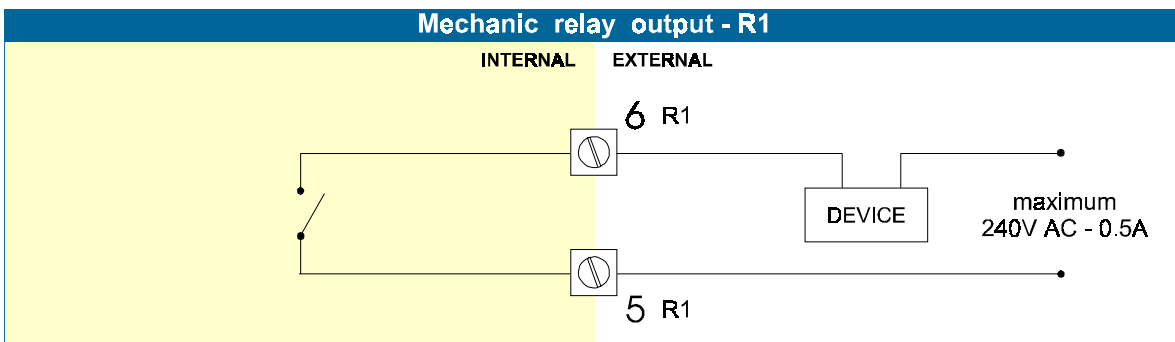

Terminal 07-08 POWER SUPPLY TYPE PX - output loop powered:

Connect an external power supply of 8-24 volts AC or 8-30VDC to these terminals or a 4-20mA loop. For a DC supply: connect the "-" to terminal 7 and the "+" to terminal 8. When power is applied to these terminals, the (optional) internal battery will be disabled / enabled automatically to extend the battery life time. (Only valid for standard passive output).

Terminal 07-08 analog output (passive) (SETUP 6) :

A 4-20mA current-sinking signal proportional to the flowrate is available as standard.

A DC power supply should be connected to terminal 07 and 08, the current is then regulated by unit. This DC supply is also used to power the unit (output loop-powered). When a power supply is connected but the output is disabled, a 3.5mA signal will be generated.

Max. driving capacity 1000 Ohm.

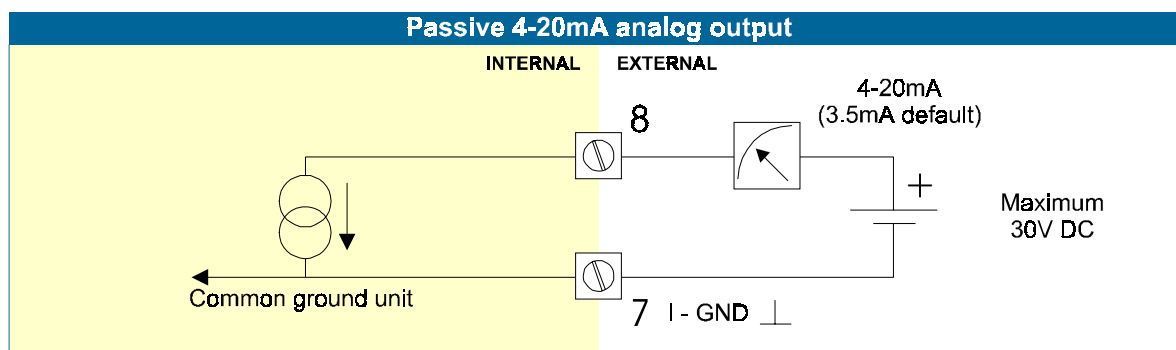
**Option AA:**

An active 4-20mA signal proportional to the flowrate is available with this option.

When the output is disabled, a 3.5mA signal will be generated on these terminals.

Max. driving capacity 1000 Ohm @ 24VDC. (Requires power supply option PD / PF / PM).

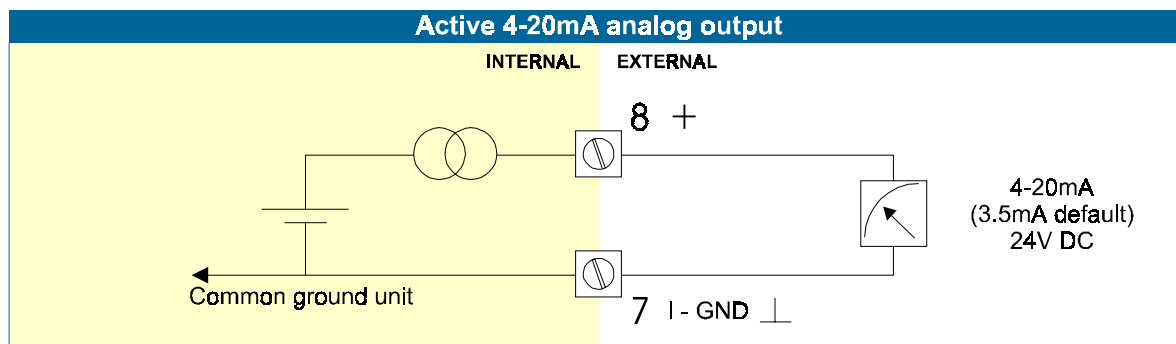
**Option AB:**

An active 0-20mA signal proportional to the flowrate is available with this option.

Max. driving capacity 1000 Ohm @ 24VDC. (Requires power supply option PD / PF / PM).

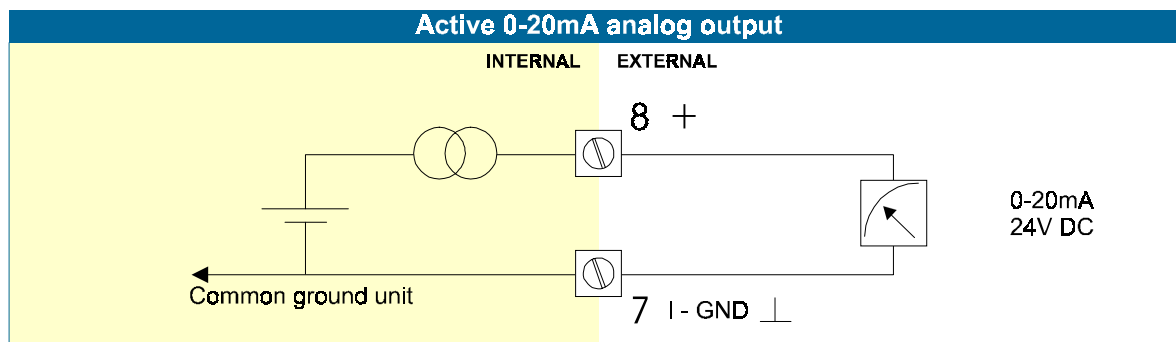

Option AF:

For the Intrinsically Safe floating 4-20mA signal: please read Chapter 5.

Option AI:

An isolated 4-20mA signal proportional to the flowrate is available with this option.

When the output is disabled, a 3.5mA signal will be generated on these terminals.

Max. driving capacity 1000 Ohm @ 30VDC.

This option can be battery powered but the life time of the battery is about 2 -3 years.

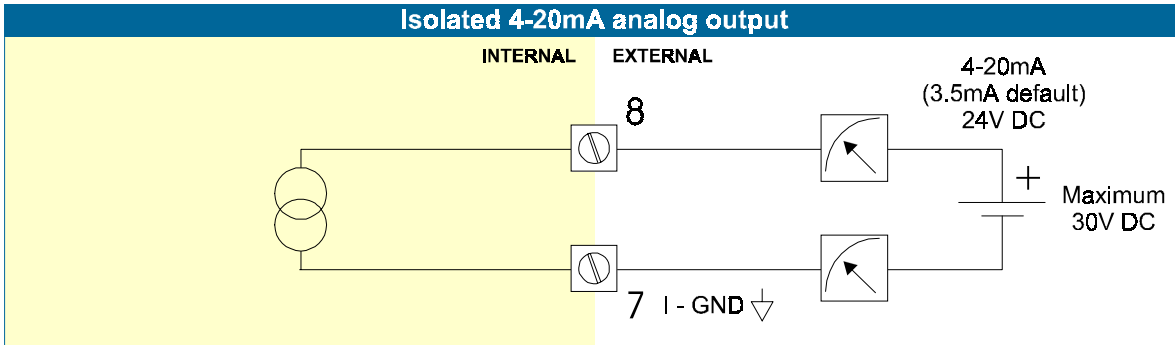

Option AU:

A 0-10VDC signal proportional to the flowrate is available with this option.

Max. load 10mA @ 10VDC. (Requires power supply option PD / PF / PM).

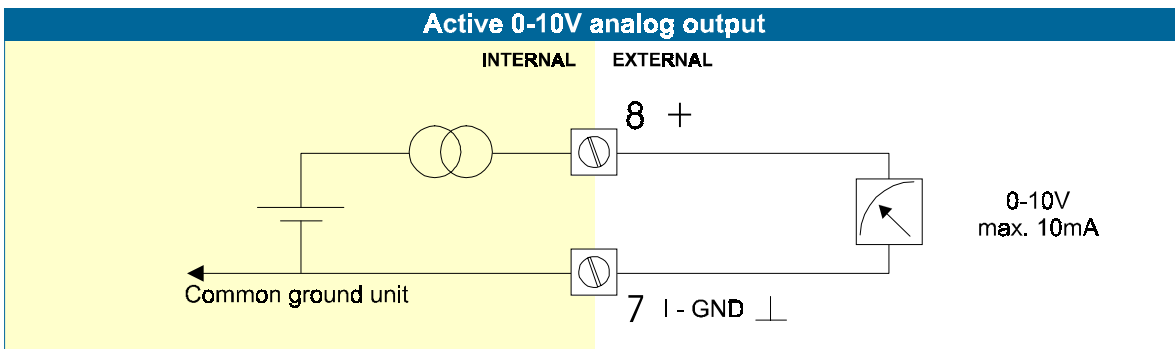

Terminal 09-11; Flowmeter input:

Three basic types of flowmeter signals can be connected to the unit: pulse, active pulse or coil. The screen of the signal wire must be connected to the common ground terminal 09. (unless earthed at the sensor itself) The maximum input frequency is approximately 10 kHz (depending on the type of signal). The input signal type has to be selected with the correct SETUP-function (read par. 3.2.3.)

Coil-signal:

The F110-P is suitable for use with flowmeters which have a coil output signal. Two sensitivity levels can be selected with the SETUP-function:

COIL LO: sensitivity from about 120mV peak to peak.

COIL HI: sensitivity from about 20mV peak to peak.

Option ZF offers for setting COIL HI : sensitivity from about 10mV peak to peak.

Option ZG offers for setting COIL HI : sensitivity from about 5mV peak to peak.

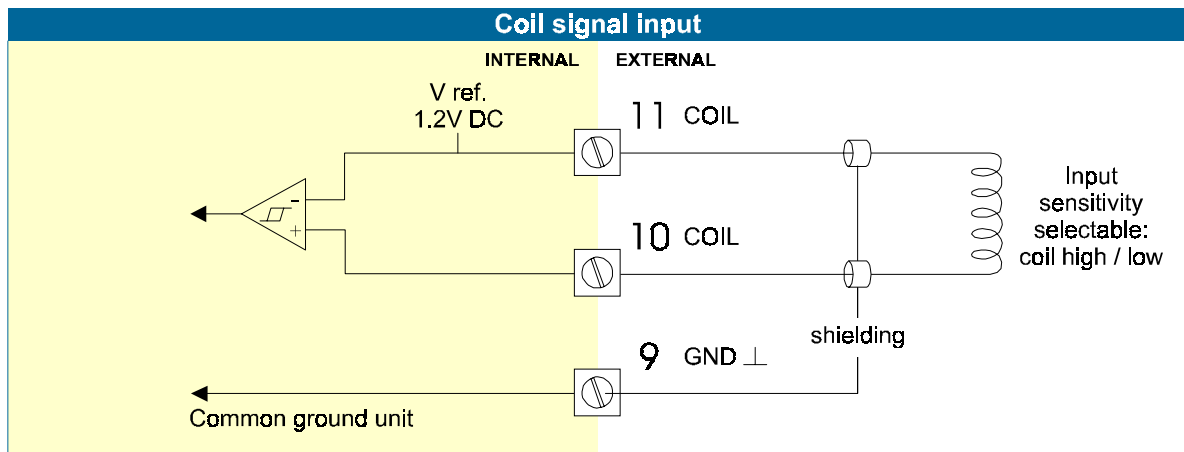
**Pulse-signal NPN / NPN-LP:**

The F110-P is suitable for use with flowmeters which have a NPN output signal. For reliable pulse detection, the pulse amplitude has to go below 1.2V. Signal setting NPN-LP employs a low-pass signal noise filter, which limits the maximum input frequency - read par. 3.2.3.

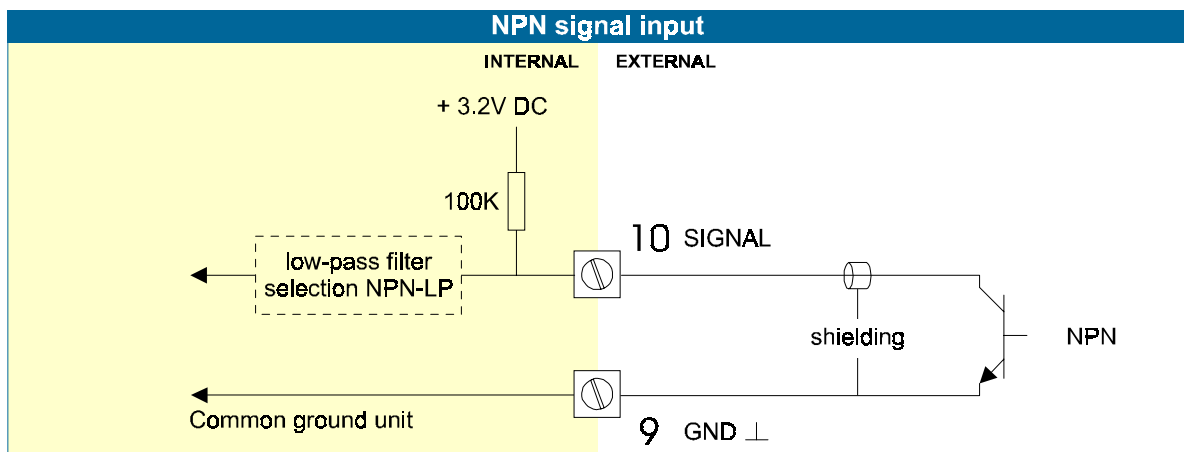

Pulse-signal PNP / PNP-LP:

The F110-P is suitable for use with flowmeters which have a PNP output signal. 3.2V is offered on terminal 11 which has to be switched by the sensor to terminal 10 (SIGNAL). For a reliable pulse detection, the pulse amplitude has to go above 1.2V. Signal setting PNP-LP employs a low-pass signal noise filter, which limits the maximum input frequency - read par. 3.2.3. A sensor supply voltage of 8.1 -12 or 24V DC can be provided via options PD-PM. For a signal detection level of 50% of the supply voltage: please refer to "active signals".

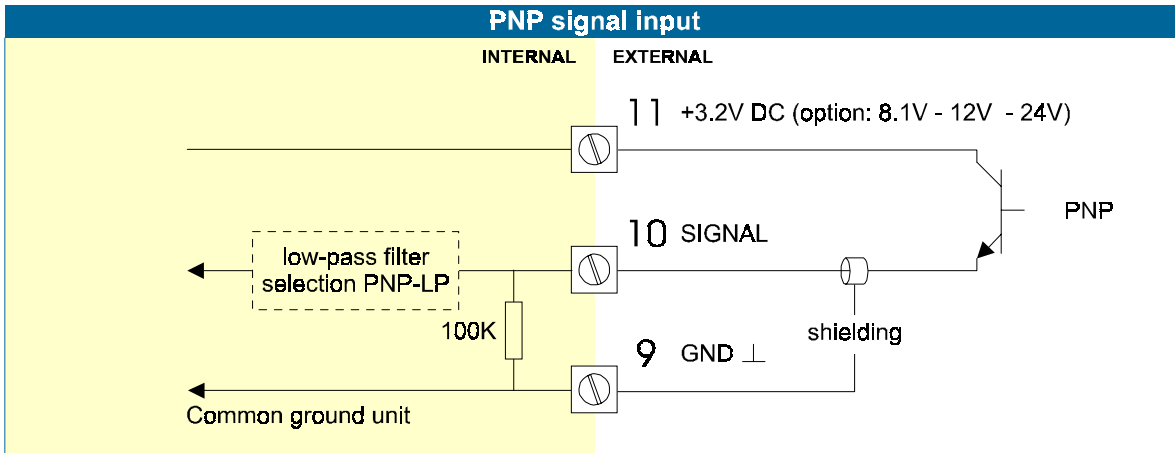

Active signals 8.1V - 12V and 24V:

If a sensor gives an active signal, please read par. 3.2.3. The detection levels are 50% of the selected supply voltage; approximately 4V (ACT_8.1) or 6V (ACT_12) or 12V (ACT_24). Active signal selection may well be desired in the case of options PD-PM being supplied for sensor supply.

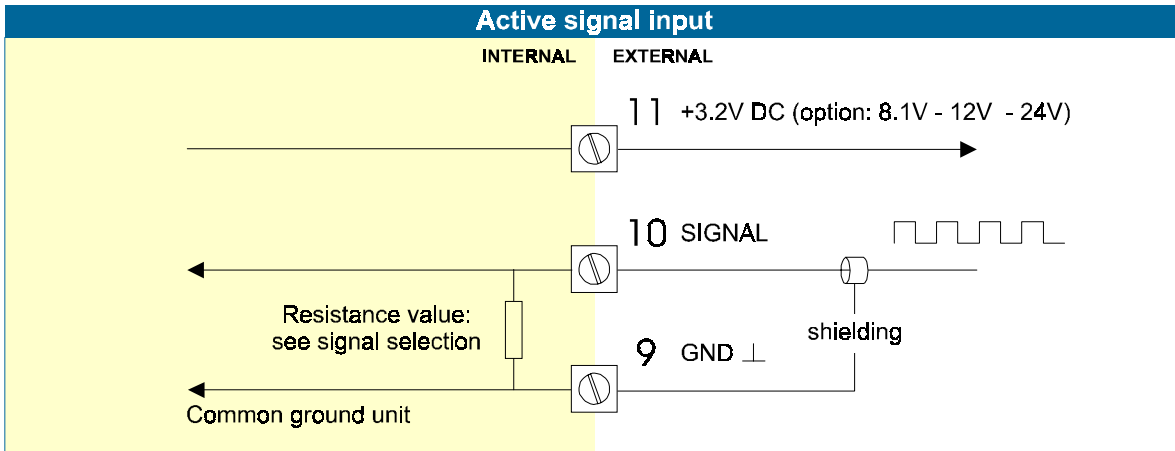

Reed-switch:

The F110-P is suitable for use with flowmeters which have a reed-switch. To avoid pulse bounce from the reed-switch, it is advised to select REED LP - low-pass filter (read par. 3.2.3.)

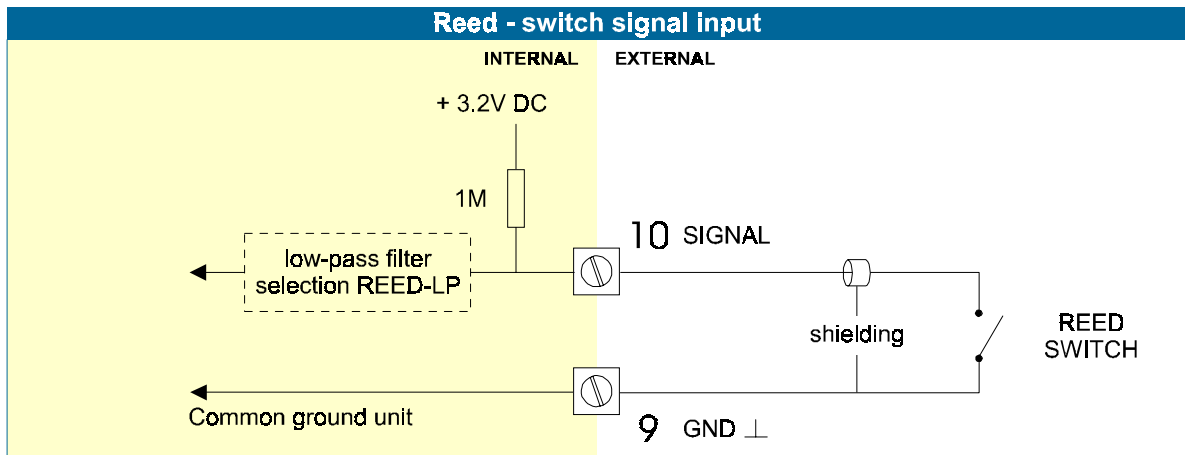

NAMUR-signal:

The F110-P is suitable for flowmeters with an Namur signal. The standard F110-P is not able to power the Namur sensor, as an external power supply for the sensor is required. However, a 8.2V sensor supply voltage (terminal 11) can be provided via options PD-PM.

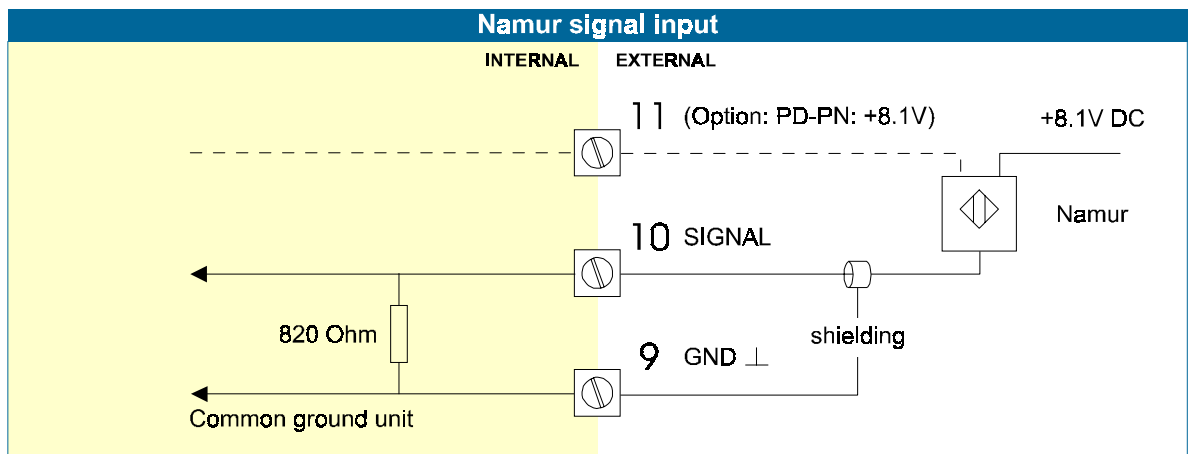

Option - Terminal 12-13; external reset:

With this function, the total can be reset to zero with an external switch. The input must be switched with a potential free contact to the GND-terminal number 12.

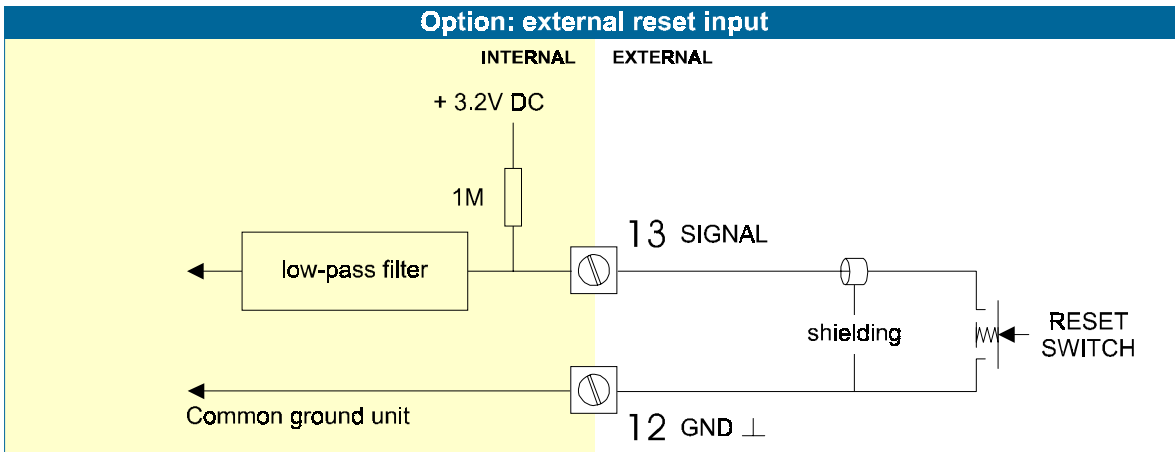

Type CB / CH / CI / CT - communication RS232/RS485:
see the manufacturer's plate.

- Full serial communications and computer control in accordance with RS232 (length of cable max. 15 meters) or RS485 (length of cable max. 1200 meters) is possible.
- Read the Modbus communication protocol and Appendix C.

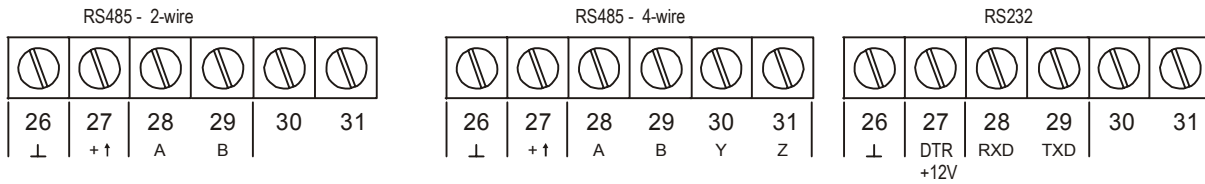

Fig. 12: Overview terminal connectors communication option.

When using the RS232 communication option, terminal 27 is used for supplying the interface. Please connect the DTR (or the RTS) signal of the interface to this terminal and set it active (+12V). If no active signal is available it is possible to connect a separate supply between terminals 26 and 27 with a voltage between 8V and 24V.

Option ZB: backlight - terminal 26-31

To power the backlight, provide a 12-24V DC to terminal 26 (-) and 27 (+). An external trimmer 1kOhm trimmer can be used to tune the brightness of the backlight, or if not desired, a short-cut between these terminals have to be made which will result in the maximum brightness.

Note: Intrinsically Safe as well as 4-wire RS485 communication is not possible in combination with option ZB.

Option type ZB: adjustable backlight

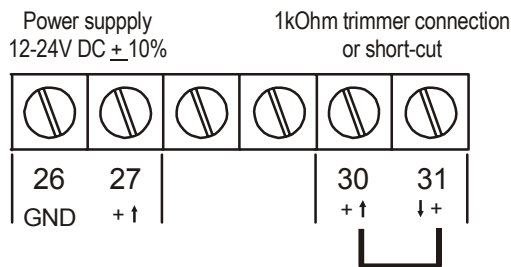

5. INTRINSICALLY SAFE APPLICATIONS



- **Mounting, electrical installation, start-up and maintenance of this device may only be carried out by trained personnel authorized by the operator of the facility. Personnel must read and understand this Operating Manual before carrying out its instructions.**
- **This device may only be operated by personnel who are authorized and trained by the operator of the facility. All instructions in this manual are to be observed.**
- **Ensure that the measuring system is correctly wired up according to the wiring diagrams. Protection against accidental contact is no longer assured when the housing cover is removed or the cabinet has been opened (danger of electric shock). The housing may only be opened by trained personnel.**
- **Take careful notice of the " Safety rules, instructions and precautionary measures " in the front of this manual.**

Safety Instructions



- **For European Community: the installation of this intrinsically safe device must be in accordance with the Atex directive 94/9/EC.**
- **This device has to be installed in accordance with the product certificate KEMA 03ATEX1074 X**
- **Exchange of Intrinsically Safe battery - certified KEMA 03ATEX1071 U - is allowed in Hazardous Area.**

Please note



- **Special conditions for safe use mentioned in both the certificate and the installation instructions must be observed for the connection of power to both input and / or output circuits.**
- **When installing this device in hazardous areas, the wiring and installation must comply with the appropriate installation standards for your industry.**
- **Study the following pages with wiring diagrams per classification.**

Serial number and year of production

This information can be looked-up on the display: setup function (par. 3.2.2.).

YEAR	WEEK	NUMBER
03	24	167
<small>SETUP</small> 93 SERIALNR		

Terminal connectors F110-P-XI:

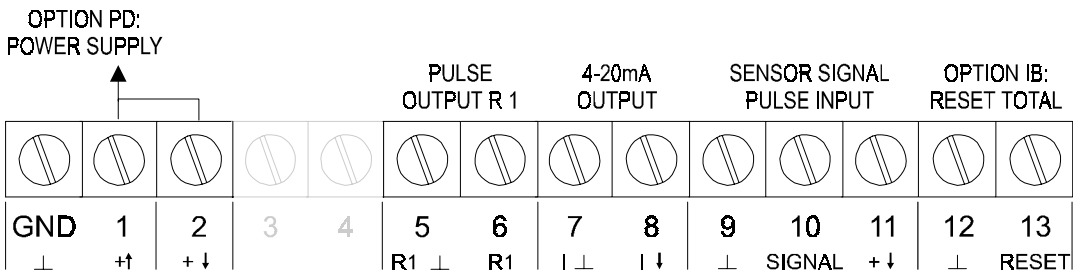
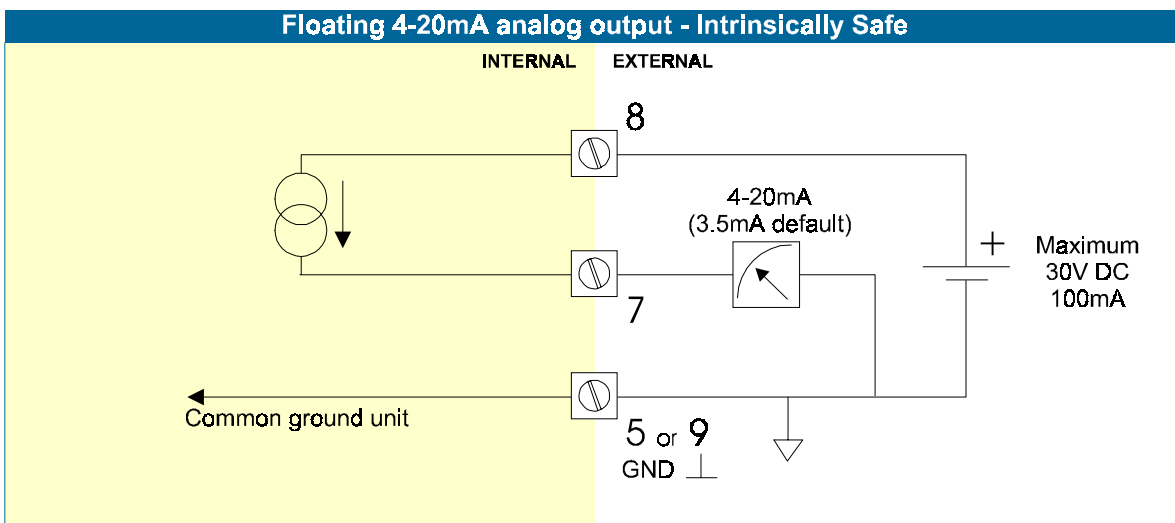

Fig. 13: Overview terminal connectors XI - Intrinsically Safe applications.

Explanation Intrinsically Safe options:

Option AF - Intrinsically Safe floating 4-20mA analog output:

A floating 4-20mA signal proportional to the flowrate is available with this option. When the output is disabled, a 3.5mA signal will be generated. Max. driving capacity 1000 Ohm @ 30V DC.



Option PD - Intrinsically Safe power supply and sensor supply - Terminal GND- 01 and 11.

OPTION	SENSOR SUPPLY	Terminal			
		GND	01	02	
PD	Input voltage: 8-30V DC	3,2 - 8,1V	L-	L+	output voltage is according the input voltage; internally linked with terminal 01.

Terminal 02: this terminal offers the same voltage as connected to terminal 01.

Terminal 11: this terminal offers a 3.2V or 8.1V to power the sensor.

This voltage is selected with the switch(es) inside the enclosure. First, remove the terminals after which the internal plastic cover can be removed.

Switch position terminal 11		Switch position no function	
SWITCH 1	VOLTAGE	SWITCH 2	
on	8.1 V DC	not available	
off	3.2 V DC		

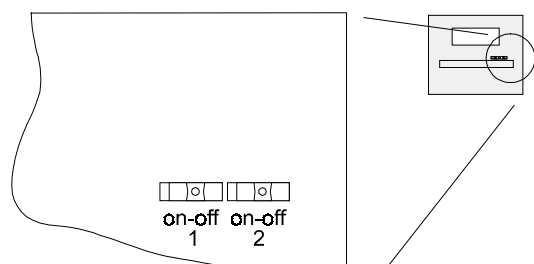

Fig. 14: Switch position voltage selection option PD-XI.

Configuration example no. 1

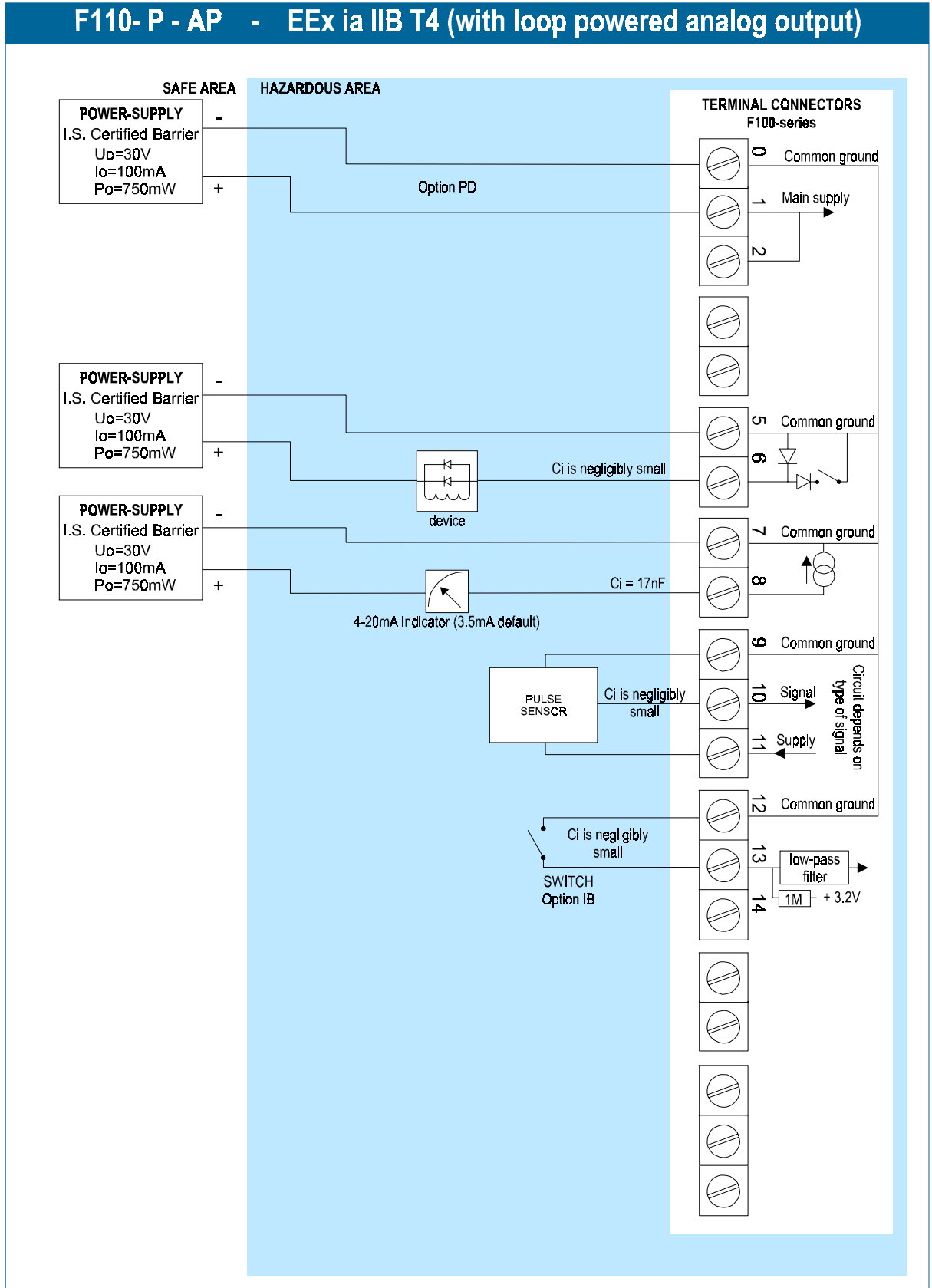

Fig. 15: Configuration example Intrinsically Safe IIB no. 1.

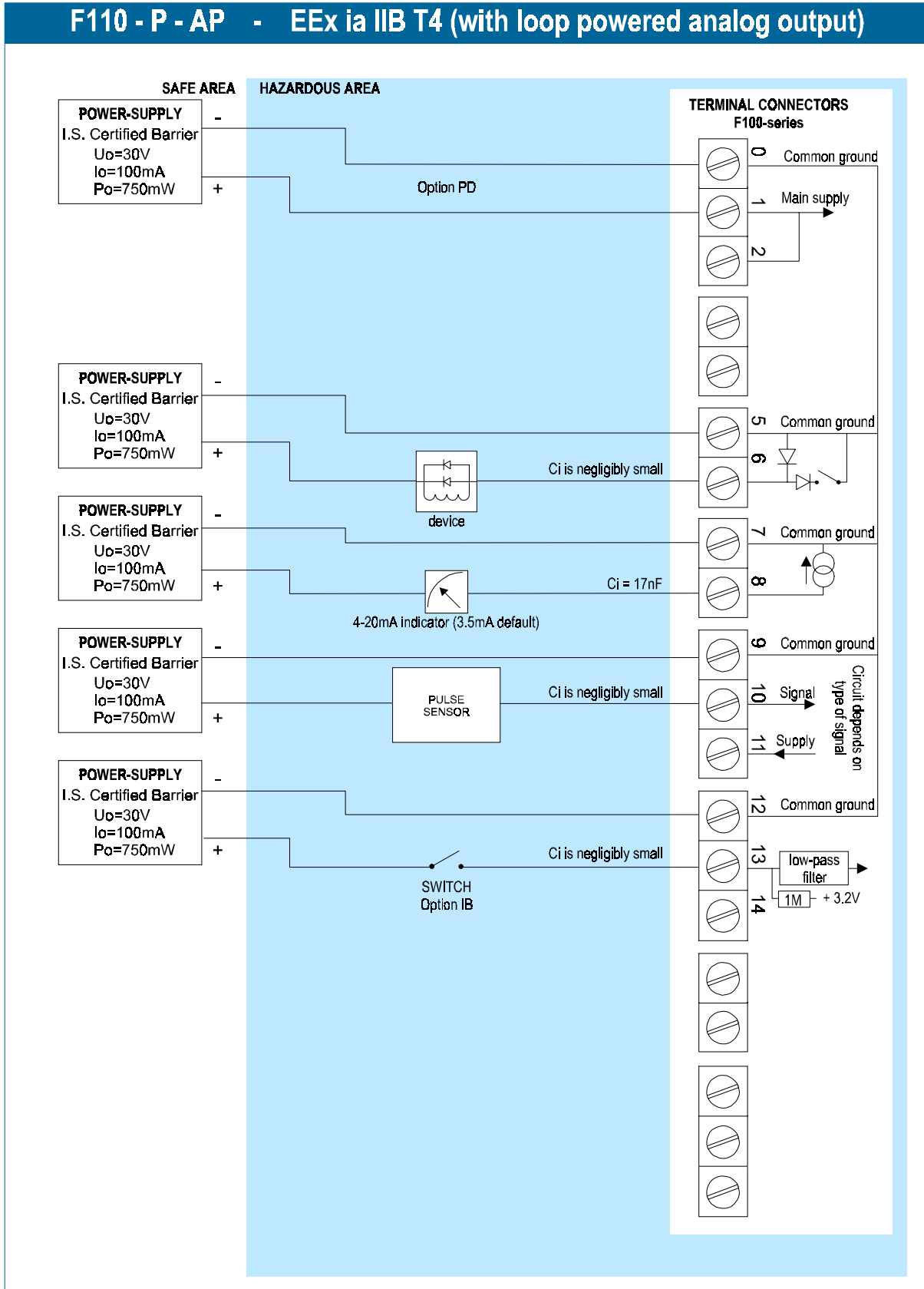

Fig. 16: Configuration example Intrinsically Safe IIB no. 2.

Configuration example no. 3

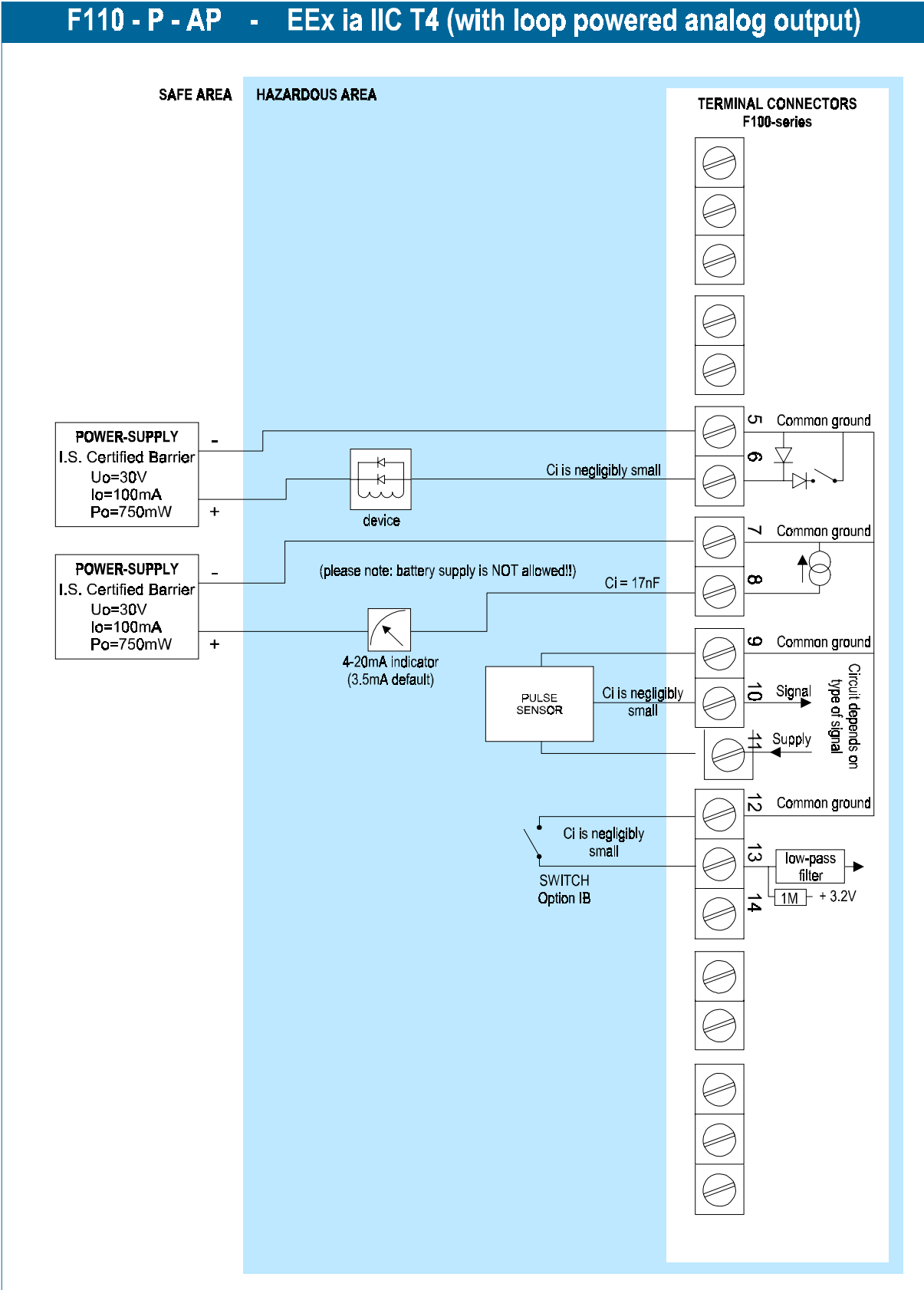

Fig. 17: Configuration example Intrinsically Safe IIC no. 3.

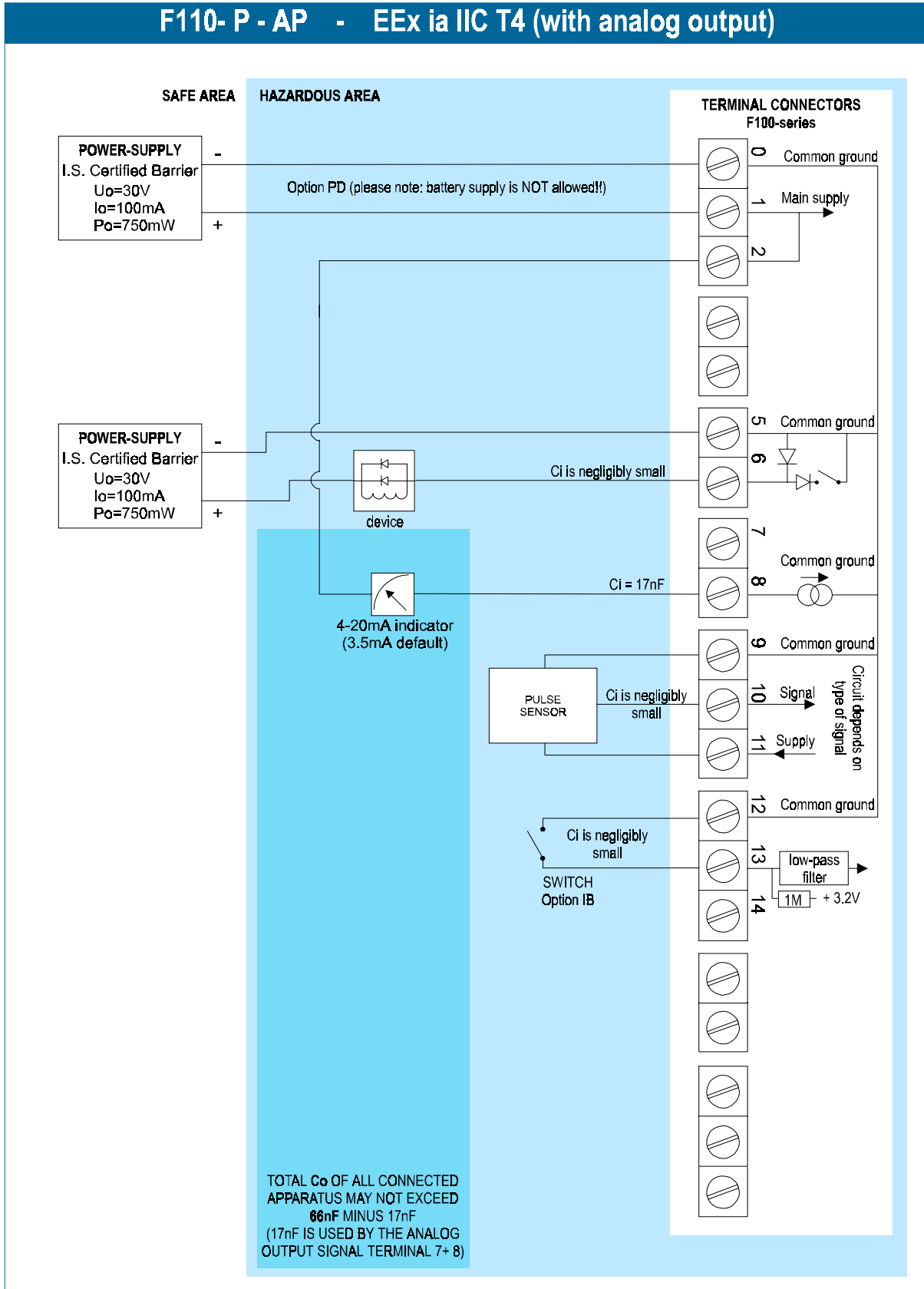

Fig. 18: Configuration example Intrinsically Safe IIC no. 4.

Configuration example no. 5

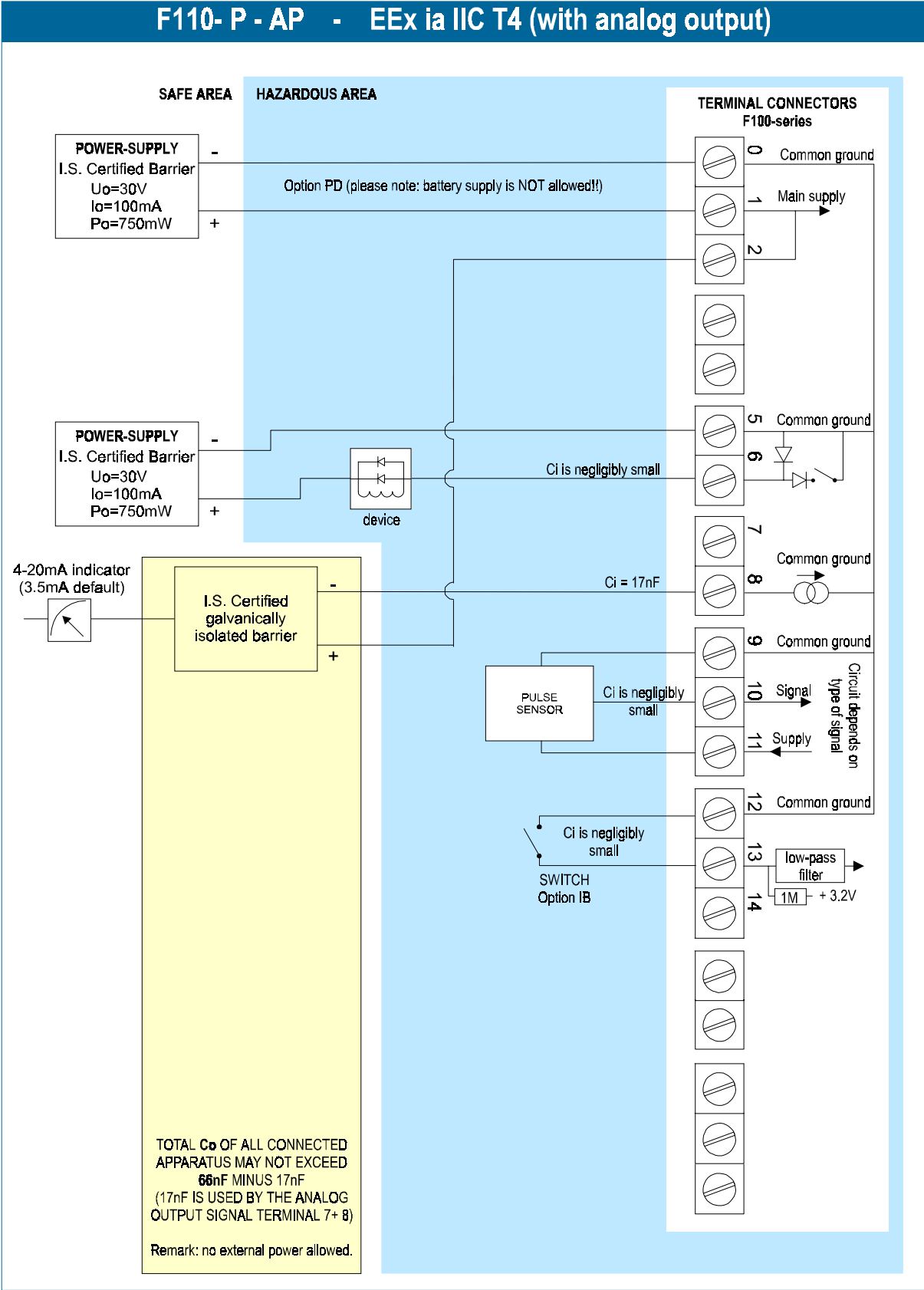

Fig. 19: Configuration example Intrinsically Safe IIC no. 5.

Configuration example no. 6

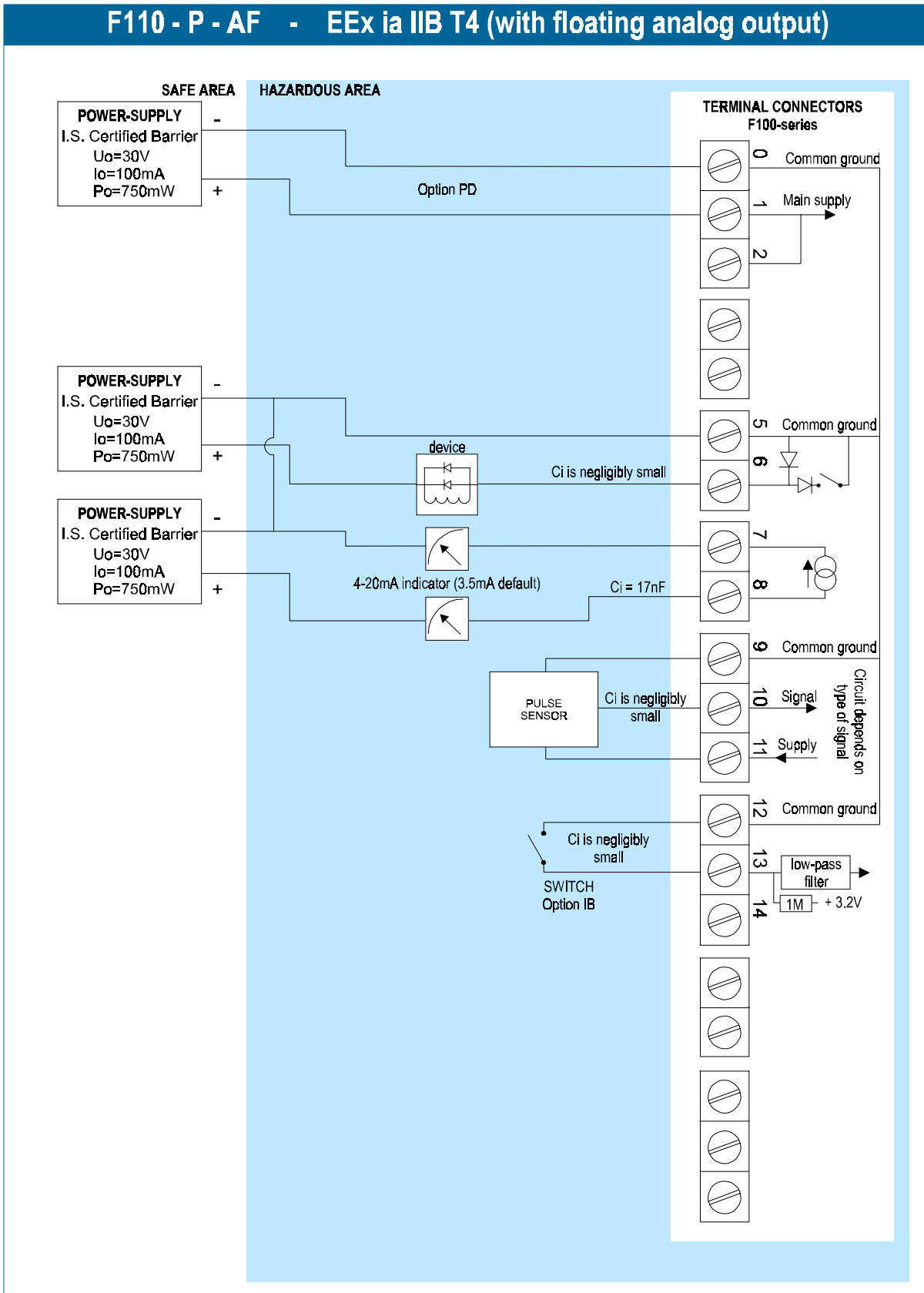

Fig. 20: Configuration example Intrinsically Safe IIB no. 6.

Configuration example no. 7

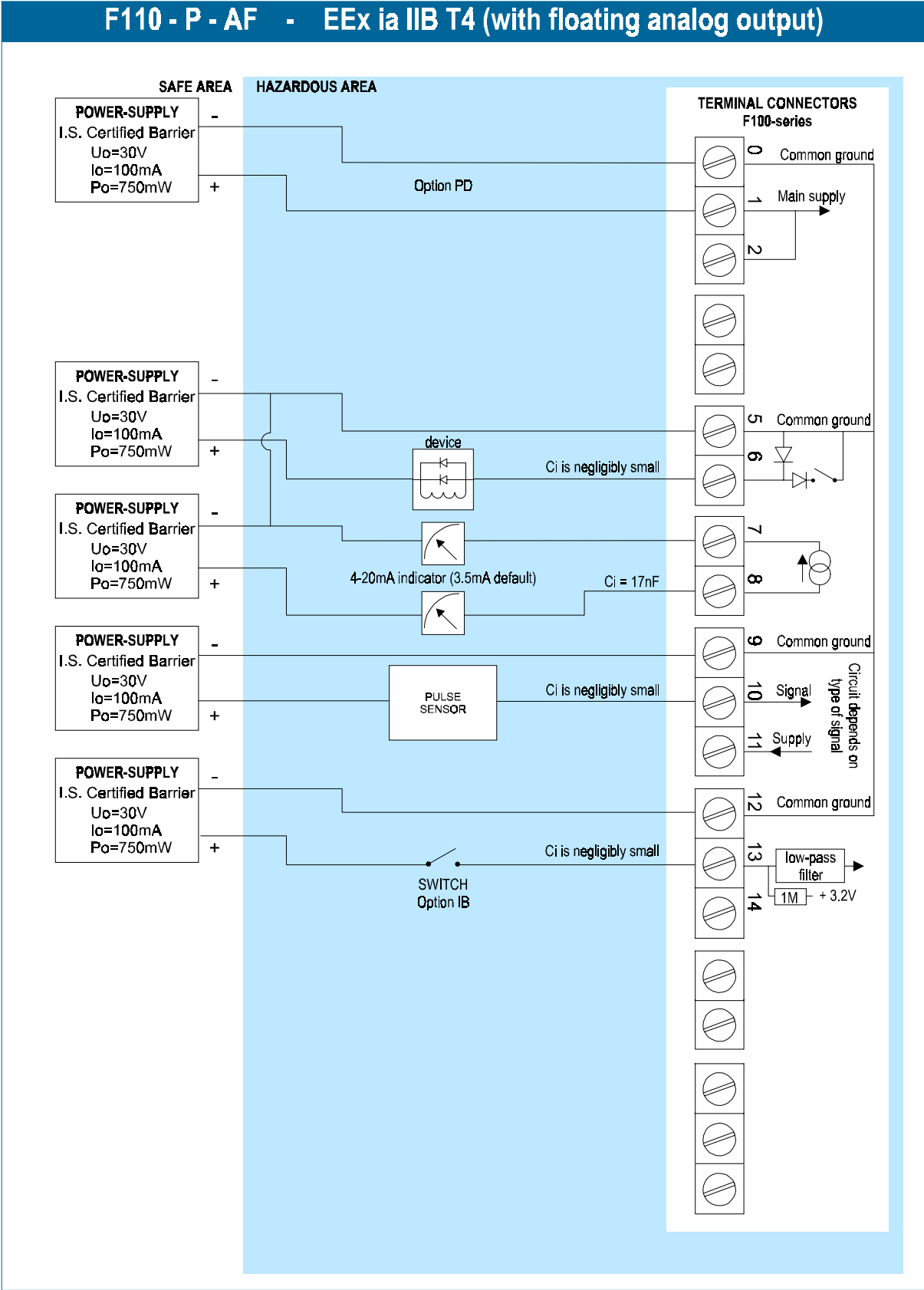

Fig. 21: Configuration example Intrinsically Safe IIB no. 7.

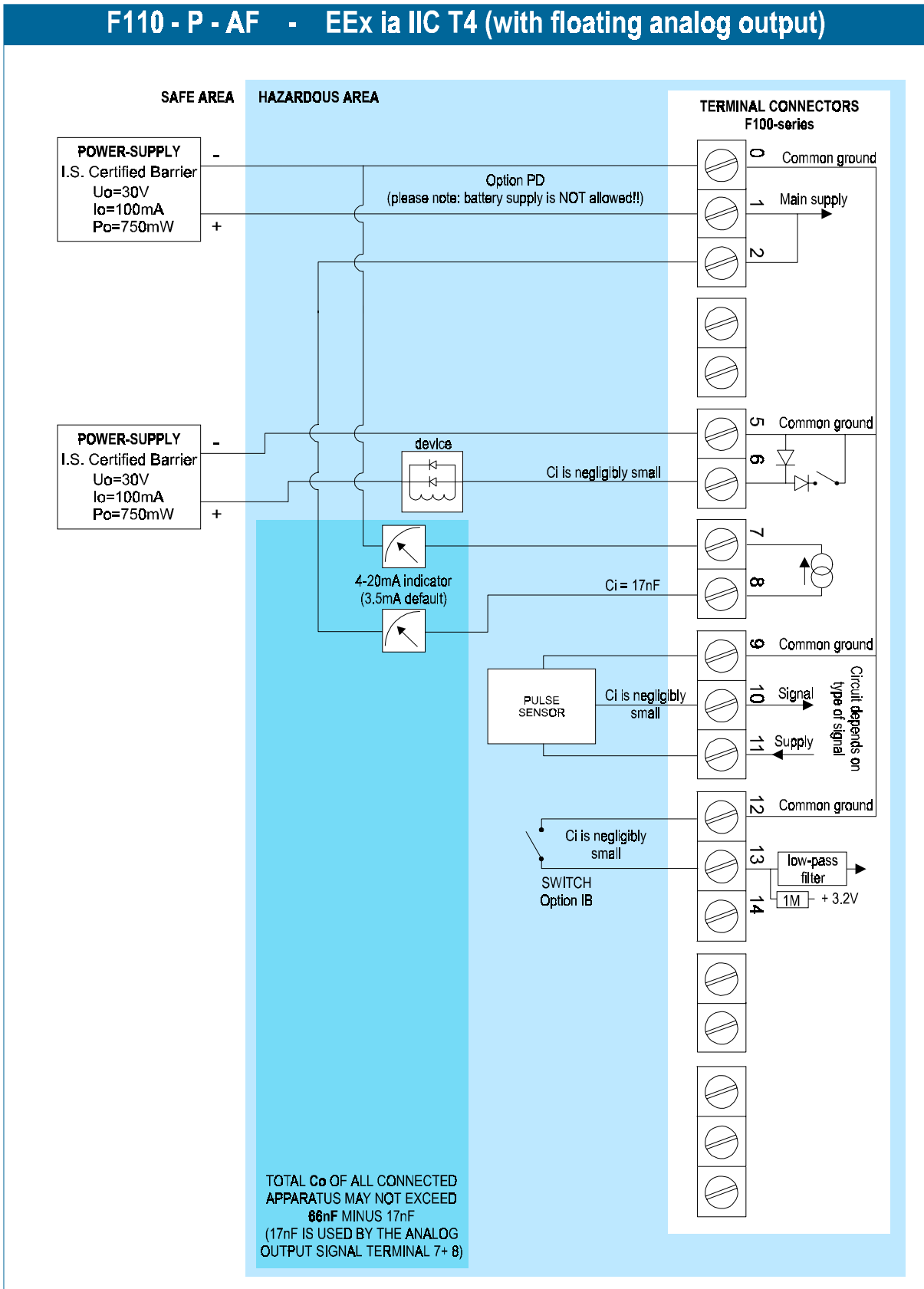

Fig. 22: Configuration example Intrinsically Safe IIC no. 8.

6. MAINTENANCE

6.1. GENERAL DIRECTIONS



- *Mounting, electrical installation, start-up and maintenance of the instrument may only be carried out by trained personnel authorized by the operator of the facility. Personnel must read and understand this Operating Manual before carrying out its instructions.*
- *The F110-P may only be operated by personnel who are authorized and trained by the operator of the facility. All instructions in this manual are to be observed.*
- *Ensure that the measuring system is correctly wired up according to the wiring diagrams. Protection against accidental contact is no longer assured when the housing cover is removed or the panel cabinet has been opened (danger from electrical shock). The housing may only be opened by trained personnel.*
- *Take careful notice of the " Safety rules, instructions and precautionary measures " in the front of this manual.*

The F110-P does not require special maintenance unless it is used in low-temperature applications or surroundings with high humidity (above 90% annual mean). It is the users responsibility to take all precautions to dehumidify the internal atmosphere of the F110-P in such a way that no condensation will occur, for example by placing dry silica-gel sachet in the casing just before closing it. Furthermore, it is required to replace or dry the silica gel periodically as advised by the silica gel supplier.

Battery life-time:

It is influenced by several issues :

- Type of sensor: read chapter 3.2.3. NPN and PNP inputs consume more energy than coil inputs.
- Input frequency: the higher the frequency, the shorter the battery life-time.
- Flowrate calculation: the lower number of pulses (SETUP 26) the shorter the battery life-time.
- Analog output signal; be sure that an external power supply is connected or that the function is disabled if not in use; or else it will have a major influence on the battery life-time (SETUP 61).
- Display update: fast display update uses significantly more power; SETUP 41.
- Pulse output and communications .
- Low temperatures; the available power will be less due to battery chemistry.



Note: *It is strongly advised to disable unused functions.*

Check periodically:

- The condition of the casing, cable glands and front panel.
- The input/output wiring for reliability and aging symptoms.
- The process accuracy. As a result of wear and tear, re-calibration of the flowmeter might be necessary. Do not forget to re-enter any subsequent K-factor alterations.
- The indication for low-battery.
- Clean the casing with soapy-water. Do not use any aggressive solvents as these might damage the polyester coating.

APPENDIX A: TECHNICAL SPECIFICATION

GENERAL

Display	
Type	High intensity reflective numeric and alphanumeric LCD, UV-resistant.
Digits	Seven 17mm (0.67") and eleven 8mm (0.31"). Various symbols and measuring units.
Refresh rate	User definable: 8 times/sec - 30 secs.
Option ZB	LED-backlight

Casing	
Type	ABS - IP65 / NEMA 4, UV-resistant and flameproof.
Mounting	Standard panel-mount case.
Dimensions	130 x 114 x 52mm (5.1" x 4.5" x 2.05") - LxHxD.
Panel cut-out	115 x 96mm (4.53" x 3.78") LxH.
Window	Polycarbonate window.
Sealing	EPDM and PE.
Control keys	Three industrial micro-switch keys. UV-resistant polyester keypad.
Type HA / HU	Die-cast aluminum IP67 / NEMA 4X with 2-component UV-resistant coating.
Dimensions	130 x 114 x 58mm (5.1" x 4.5" x 2.28") - LxHxD.
Mounting	Wall-mount, sensor head-mount, panel-mount, horizontal/vertical pipes.
Cable Entry	HA: 2xPG9 and 1xM20 tapped hole in the center. HU: 3x ½"NPT tapped hole.
Type HD	ABS IP67 / NEMA 4X wall-mount casing.
Dimensions	130 x 114 x 71mm (5.1" x 4.5" x 2.8") - LxHxD.
Cable Entry	None. User defined.

Operating temperature	
Operational	-30°C to +80°C (-22°F to +178°F).

Power requirements	
Standard	Output loop powered: 8-28V DC (or AC) supply can be connected to power the unit.
Type PB	Long life Lithium battery - life-time depends upon settings - up to 5 years.
Type PD	8-28 V AC/DC.
Type PF	24-28V AC/DC.
Type PM	80-240V AC.

Sensor excitation	
Standard / Type PB	Supply voltage: 3.2V DC for pulse signals and 1.2V DC for coil pick-up.
Type PD	Sensor supply: 8.2 - 12 and 24V DC - max. 50mA@24V DC
Type PF/PM	Sensor supply: 8.2 - 12 and 24V DC - max. 100mA@24V DC

Terminal connections	
Type:	Removable plug-in terminal strip. Wire max. 1.5mm ² and 2.5mm ² (Type PM / PF)

Data protection	
Type	EEPROM backup of all setting. Backup of running totals every minute. Data retention at least 10 years.
Pass code	Configuration settings can be pass code protected.

Hazardous area (optional)	
Intrinsically safe Type XI	ATEX approval ref: II 1 GD EEx ia IIB/IIC T4. Maximum ambient +70°C (158°F).
Explosion proof Type XD/XF	ATEX approval ref: II 2 G EEx d IIB T5. Weight appr. 20kg. Dimensions of enclosure: 278 x 358 x 270mm (10.94" x 14.09" x 10.63") LxHxD.

Environment	
Electromagnetic compatibility	Compliant ref: EN 61326 (1997), EN 61010-1 (1993).

INPUTS

Flowmeter	
Type P	Coil/sine wave (minimum 20mVpp or 80mVpp - sensitivity selectable), NPN/PNP, open collector, reed-switch, Namur, active pulse signals 8 - 12 and 24V.
Frequency	Minimum 0 Hz - maximum 7 kHz for total and flowrate. Maximum frequency depends on signal type and internal low-pass filter. E.g. Reed switch with low-pass filter: max. frequency 120 Hz.
K-Factor	0.000010 - 9,999,999 with variable decimal position.
Low-pass filter	Available for all pulse signals.
Type A	(0)4-20mA - with signal calibration feature. Resolution: 14 bit.
Type U	0-10 V - with signal calibration feature at any voltage within range. Resolution: 14 bit.
Accuracy	0.05%. Low level cut-off programmable.
Span	0.000010 - 9,999,999 with variable decimal position.
Update time	Four times a second.
Voltage drop	2.5 Volt.
Load impedance	3kOhm
Relationship	Linear and square root calculation.
Note	For signal type A and U: external power to sensor is required; e.g. Type PD.

OUTPUTS

Analog output	
Type	4-20mA - passive output - not isolated.
Resolution	10-bit.
Accuracy	< 0.05% - update 10 times a second. Software function to calibrate the 4.00mA and 20.00mA levels precisely within set-up.
Load	max. 1 kOhm
Function	transmitting flowrate.
Type AA	Active 4-20mA output (requires Type PD, PF or PM).
Type AB	Active 0-20mA output (requires Type PD, PF or PM).
Type AF	Floating 4-20mA output for Intrinsically Safe applications
Type AI	Galvanically isolated output - also for battery powered models.
Type AU	Active 0-10V output (requires Type PD, PF or PM).

Transistor output(s)	
Type OT	one passive transistor outputs - not isolated.
Load	max. 50V - 300mA
Function	pulse output - transmitting accumulated total.
Pulse output	Max. frequency 60Hz. Pulse length user definable between 7,8msec up to 2 seconds.
Type OA	Active 24V DC output; max. 50mA per output (requires Type PD, PF or PM).
Type OR	Electro-mechanical relay output; max. switch power 230V AC - 0,5A (requires Type PF or PM).

Communication option	
Type	RS232 or RS485 (2-wire or 4-wire).
Protocol	Modbus ASCII / RTU
Speed	1200 - 2400 - 4800 - 9600 baud
Addressing	maximum 255 addresses.
Functions	reading display information, reading / writing all settings.

OPERATIONAL

Operator functions

Displayed functions	<ul style="list-style-type: none"> total and/or flowrate. total and accumulated total. total can be reset to zero by pressing the CLEAR-key twice.
---------------------	---

Total

Digits	7 digits.
Units	L, m3, GAL, USGAL, KG, lb, bbl, no unit.
Decimals	0 - 1 - 2 or 3.
Note	total can be reset to zero.

Accumulated total

Digits	11 digits.
Units / decimals	according to selection for total.

Flowrate

Digits	7 digits.
Units	mL, L, m3, Gallons, KG, Ton, lb, bl, cf, RND, ft3, scf, Nm3, NI, igal - no units.
Decimals	0 - 1 - 2 or 3.
Time units	/sec - /min - /hr - /day.

APPENDIX B: PROBLEM SOLVING

In this appendix, several problems are included that can occur when the F110-P is going to be installed or while it is in operation.

Flowmeter does not generate pulses:

Check:

- Signal selection SETUP - 51,
- Pulse amplitude (par. 4.4.3.),
- Flowmeter, wiring and connection of terminal connectors (par. 4.4.3.),
- Power supply of flowmeter (par. 4.4.2.).

Flowmeter generates "too many pulses":

Check:

- Settings for total and Flowrate: SETUP 11-14 and 21-27,
- Type of signal selected with actual signal generated - SETUP - 51,
- Sensitivity of coil input - SETUP - 51 and par. 4.4.3.
- Proper grounding of the F110-P - par. 4.4.1.
- Use screened wire for flowmeter signals and connect screen to terminal 9. (unless connected at sensor)

Analog output does not function properly:

Check:

- SETUP 61 - is the function enabled?
- SETUP 62 / 63: are the flow-levels programmed correctly?
- connection of the external power-supply according to the specification.

Pulse output does not function:

Check:

- SETUP 71 - pulse per "x" quantity; is the value programmed reasonable and will the maximum output be under 20Hz?
- SETUP 72 - impulse width; is the external device able to recognize the selected pulse width and frequency?

Flowrate displays "0 / zero" while there is flow (total is counting):

Check:

- SETUP 22 / 25: are the K-factor and time unit correct?
- SETUP 26 / 27: The unit has to count the number of pulses according to SETUP 26 within the time according to SETUP 27. Make sure that 27 is set to 10.0 seconds for example : the result is that the unit has at least 10 seconds time to measure the number of pulses according to SETUP 26.

The pass code is unknown:

If the pass code is not 1234, there is only one possibility left: call your supplier.

ALARM

When the alarm flag starts to blink an internal alarm condition has occurred. Press the "select button" several times to display the 5-digit error code. The codes are:

0001: irrecoverable display-data error: data on the display might be corrupted.

0002: irrecoverable data-storage error: the programming cycle might have gone wrong: check programmed values.

0003: error 1 and error 2 occurred simultaneously

The alarm condition will almost certainly be handled internally and if all mentioned values still appear correct, no intervention by the operator is needed. If the alarm occurs more often or stays active for a longer time, please contact your supplier.

APPENDIX C: COMMUNICATION VARIABLES

Remarks:

- Below, an overview of the F110-P specific variables; other common variables are described in the standard table.
- All numbers are decimal numbers, unless otherwise noted.
- The following variables of the standard table (var00-var30) are not valid for this product and will be responded with value 1: var00, 03-05, 07,08, 16-22, 24, 26-29.

CONFIGURATION VARIABLES F110-P - SETUP-LEVEL:				
VAR	DESCRIPTION	BYTES	VALUE	REMARKS
TOTAL				
32 (20h)	unit	1	0=L 1=m3 2=kg 3=lb 4=gal 5=usgal 6=bbbl 7=none	
33 (21h)	decimals	1	0...3	
34 (22h)	K-factor	3	1....9.999.999	K-f 0000001 - K-f 0000009 is allowed when decs < 6! (VAR37)
37 (25h)	decimals K-factor	1	0...6	
FLOWRATE				
48 (30h)	unit	1	0=mL 1=L 2=m3 3=mg 4=g 5=kg 6=ton 7=gal 8=bbbl 9=lb 10=cf 11=rev (revolutions for RPM) 12=none 13=scf 14=NM3 15=NL 16=p	
49 (31h)	time unit	1	0=sec 1=min 2=hour 3=day	
50 (32h)	decimals	1	0...3	
51 (33h)	K-factor	3	1....9.999.999	K-f 0000001 - K-f 0000009 is allowed when decs < 6! (VAR54)
54 (36h)	decimals K-factor	1	0...6	
55 (37h)	number of pulses	1	1..255	
56 (38h)	cut-off time	2	1 .. 9999	steps of 100ms

VAR	DESCRIPTION	BYTES	VALUE	REMARKS
DISPLAY				
64 (40h)	display function	1	0=total 1=flowrate	
68 (44h)	set flowrate monitor	1	0=operator level 1=SETUP level	
POWERMANAGEMENT				
80 (50h)	LCD update time	1	0=fast 1=1sec 2=3sec 3=15sec 4=30sec 5=off	
81 (51h)	power-mode battery	1	0=operational 1=shelf	
FLOWMETER				
96 (60h)	flowmeter signal	1	0=npn 1=npn-lp 2=reed 3=reed LP 4=pnp 5=pnp-lp 6=namur 7=coil hi 8=coil lo	
ANALOG OUTPUT				
112 (70h)	analog output	1	0=disable 1=enable	
113 (71h)	minimum rate	3	0..9999999	unit, time, decimals acc. var48-50
116 (74h)	maximum rate	3	0..9999999	unit, time, decimals acc. var48-50
119 (77h)	cut off percentage	1	0..99	steps of 0.1%
120 (78h)	tune minimum rate	2	0..9999	
122 (7Ah)	tune maximum rate	2	0..9999	
99 (63h)	filter	1	0....99	
PULSE OUTPUT				
128 (80h)	impulse width	1	0=off 1=short 2=long	
129 (81h)	pulse per X quantity	3	1..9999999	unit, decimals acc. var32 -33
OTHERS				
168 (A8h)	pass code	2	xxxx	read only!
170 AAh	tagnumber	3	0..9999999	Other vars: see standard table

OTHER F110-P VARIABLES FOR COMMUNICATION

TOTAL - variable number 566 (236h) – 6 bytes

Read total: The value of total read using RS communications might differ from the value that appears on the display. This is due to the fact that the display can only display up to seven digits (for example when two decimals are selected for total and total has a value of 123456,78 the display will show 23456,78 while communication will read a “total” of 12345678 and a “total decimals” of 2).

Write total: total can only be cleared. This means writing a value different from 0 will result in the reply of an error message. Only writing 6 bytes of zero's to total will be accepted.

ACCUMULATED TOTAL - variable number 560 (230h) – 6 bytes

Read acc. total: A difference between the read value and the display value, as explained for “Read total”, might appear here too.

Write acc. total: Not possible.

When reading or writing total or accumulated total it should be noted that the used values are given including the decimals. This means that a read/write to one of these variables should be accompanied with a read/write to the variable that holds the number of decimals for this variable:

Example: read var. 566 for total:

Read var. 33 for total decimals and calculate the real value of total by multiplying total with $10^{-(total\ decimals)}$

FLOWRATE - variable number 572 (23Ch) – 4 bytes

Read flowrate: The value difference as mentioned with total/acc. total might appear here too.

Write flowrate: Not possible.

INDEX OF THIS MANUAL

accumulated Total	8	Intrinsic safety	33
actual settings	52	Intrinsically Safe options	34
analog		IP classification	21
0-10V output	28	keys	7
floating output.	34	low-battery	9
flowrate min.	18	Low-battery alarm	9
intrinsically safe output.	34	main-function	11
isolated output.	28	maintenance	43
output loop powered.	27	model	20
passive output.	27	NAMUR-signal	31
Backlight	32	Operator level	8
battery life time	16; 43	pass code	20; 47
Clear Total	8	power supply	25
Coil-signal	29	power supply - loop powered	27
communication	32	power supply intrinsically safe	34
family-specific variables	48	Problem solving	47
terminal connection	32	pulse output	
Configuration	10	pulse length / period time	19
Dimensions	22	pulse per quantity	19
display		Pulse-signal NPN/PNP	29; 30
function	16	rate/Total	8
display update	16	Reed-switch:	31
external reset option	32	serial number	20
flowmeter		SETUP-level	10
signal	17	subfunction	11
Flowmeter input	29	tagnumber	20
flowrate		Technical specification	44
calculation	15	terminal connectors	25
decimals	15	total	
decimals k-factor	15	decimals	14
measuring unit	15	decimals k-factor	14
time unit	15	k-factor	14; 15
high alarm output	26	measuring unit	14
Installation	21	version software	20

LIST OF FIGURES IN THIS MANUAL

Fig. 1: Typical application for the F110-P.....	5
Fig. 2: Control Panel.....	7
Fig. 3: Example of display information during process.	8
Fig. 4: Example of low-battery alarm.....	9
Fig. 5: Dimensions of standard IP65 ABS Panel-mount casing / panel cut-out.....	22
Fig. 6: Dimensions for option HD: IP67 ABS Wall-mount enclosure.....	22
Fig. 7: Dimensions for option HA: IP67 Aluminum Field enclosure with 2xPG9 and 1xM20 drilling.	22
Fig. 8: Dimensions option HU: NEMA 4X Aluminum Field enclosure with 3x 1/2"NPT drilling.....	22
Fig. 9: Grounding aluminum enclosure with option PM 115-230V AC.....	23
Fig. 10: switch position voltage selection (option PD, PF and PM).....	24
Fig. 11: Overview of terminal connectors standard configuration F110-P and options.	25
Fig. 12: Overview terminal connectors communication option.....	Fout! Bladwijzer niet gedefinieerd.
Fig. 13: Overview terminal connectors XI - Intrinsically Safe applications.....	34
Fig. 14: Switch position voltage selection option PD-XI.....	34
Fig. 15: Configuration example Intrinsically Safe IIB no. 1.	35
Fig. 16: Configuration example Intrinsically Safe IIB no. 2.	36
Fig. 17: Configuration example Intrinsically Safe IIC no. 3.	37
Fig. 18: Configuration example Intrinsically Safe IIC no. 4.	38
Fig. 19: Configuration example Intrinsically Safe IIC no. 5.	39
Fig. 20: Configuration example Intrinsically Safe IIB no. 6.	40
Fig. 21: Configuration example Intrinsically Safe IIB no. 7.	41
Fig. 22: Configuration example Intrinsically Safe IIC no. 8.	42

LIST OF CONFIGURATION SETTINGS			
SETTING	DEFAULT	DATE :	DATE :
1 - TOTAL			
Enter your settings here			
11 unit	L		
12 decimals	0000000		
13 K-factor	0000001		
14 decimals K-factor	0		
2 - FLOWRATE			
21 unit	L		
22 time unit	/min		
23 decimals	0000000		
24 K-factor	0000001		
25 decimals K-factor	0		
26 calculation / pulses	010		
27 cut-off time	30.0 sec.		
3 - DISPLAY			
31 function	total		
4 - POWER MANAGEMENT			
41 LCD-new	1 sec.		
42 mode	operational		
5 - FLOWMETER			
51 signal	coil-lo		
6 - ANALOG OUTPUT			
61 output	disabled		
62 min. flowrate 4-mA	0000000		
63 max. flowrate 20mA	9999999		
64 cut off percentage	0.0%		
65 tune min - 4mA	0208		
66 tune max - 20mA	6656		
67 filter	01 (off)		
7 - PULSE OUTPUT			
71 impulse width	000 periods		
72 pulse per	0001000		
8 - COMMUNICATION			
81 baud-rate	2400		
82 address	1		
83 mode	BUS-ASC		
9 - OTHERS			
94 pass code	0000		
95 tagnumber	0000000		